

Dialog 4425 IP Vision

IP Telephone for MX-ONE™ and MD110

User Guide



ASTRA

EN/LZT 103 64 R8A

© Aastra Telecom Sweden AB 2009. All rights reserved.

Table of Contents

Welcome	4
Important User Information	6
Description	7
Start the Phone – Log On/Off	27
Incoming Calls	36
Outgoing Calls	42
Call List	52
Contacts (PhoneBook)	55
During Calls	62
Call Forwarding	67
Absence Information	77
Messages	80
Group Features	85
Other Useful Features	87
Settings	93
Accessories	108
Add Microsoft Outlook Contacts	113
Web Server	115
Corporate Directory	123
Web	125
WAP Services	127
Installation	132
Troubleshooting	141
Glossary	142
Index	143

Welcome

Welcome to the user guide for the *Dialog 4425 IP Vision* IP telephone that conforms to the H.323 standard.

This guide describes the available features of the telephone when it is connected to **MX-ONE™** or **MD110**.

The functions and features available with this telephone are designed for easy use in all different telephone handling situations.

Depending on the version and configuration of the exchange that your telephone is connected to, some of the functions and features that are described in this user guide may not be available. There may also be some differences in the way your telephone is programmed. Please consult your system administrator if you need further information.

Note: *The Dialog 4425 IP Vision exists in two versions, version 1 and version 2. Underneath the telephone, version 1 is marked DBC 425 01 and version 2 is marked DBC 425 02. Check to see which version you are using.*

Some markets use differing codes for some features. In this guide they are described using the most common code.

The latest version of the user guide can be downloaded from:
<http://www.aastra.com>

Copyright

All rights reserved. No parts of this publication may be reproduced, stored in retrieval systems, or transmitted in any form or by any means, electronic, mechanical, photocopying, recording or otherwise, without prior written permission of the publisher except in accordance with the following terms.

When this publication is made available on Aastra media, Aastra gives its consent to downloading and printing copies of the content provided in this file only for private use and not for redistribution. No parts of this publication may be subject to alteration, modification or commercial use. Aastra will not be liable for any damages arising from use of an illegal modified or altered publication.

Aastra is a registered trademark of Aastra Technologies Limited. All other trademarks mentioned herein are the property of their respective owners.

Warranty

AASTRA MAKES NO WARRANTY OF ANY KIND WITH REGARD TO THIS MATERIAL, INCLUDING, BUT NOT LIMITED TO, THE IMPLIED WARRANTIES OF MERCHANTABILITY AND FITNESS FOR A PARTICULAR PURPOSE. Aastra shall not be liable for errors contained herein nor for incidental or consequential damages in connection with the furnishing, performance or use of this material.

Declaration of conformity

Hereby, Aastra Telecom Sweden AB, SE-126 37 Hågersten, declares that this telephone is in conformity with the essential requirements and other relevant provisions of the R&TTE directive 1999/5/EC.

Details to be found at: <http://www.aastra.com/sdoc>.



Important User Information

Safety instructions

Save these instructions.



Read these safety instructions before use!

Note: *When using your telephone or connected equipment, the following basic safety precautions should always be followed to reduce risk of fire, electrical shock and other personal injury.*

- Follow instructions in the equipment's user guide or other documentation.
- Always install equipment in a location and environment for which it is designed.
- For mains powered telephones: Only operate with the mains power voltage indicated. If you are uncertain of the type of power supplied to the building, consult property management or your local power company.
- For mains powered telephones: Avoid placing the telephone's power cable where it can be exposed to mechanical pressure as this may damage the cable. If the power supply cord or plug is damaged, disconnect the product and contact qualified service personnel.
- Headsets used with this equipment must comply with EN/IEC 60950-1 and for Australia AS/NZS 60950:1-2003.
- Do not make any changes or modifications to equipment without seeking approval from the party responsible for compliance. Unauthorized changes or modifications could void the user's authority to operate the equipment.
- Do not use the telephone to report a gas leak in the vicinity of the leak.
- Do not spill liquid of any kind on the product or use the equipment near water, for example, near a bathtub, washbowl, and kitchen sink, in a wet basement or near a swimming pool.
- Do not insert any object into equipment slots that is not part of the product or auxiliary product.
- Do not disassemble the product. Contact a qualified service agency when service or repair work is required.
- Do not use a telephone (other than cordless type) during an electrical storm.

Disposal of the product



Your product should not be placed in municipal waste. Please check local regulations for disposal of electronic products.

Description

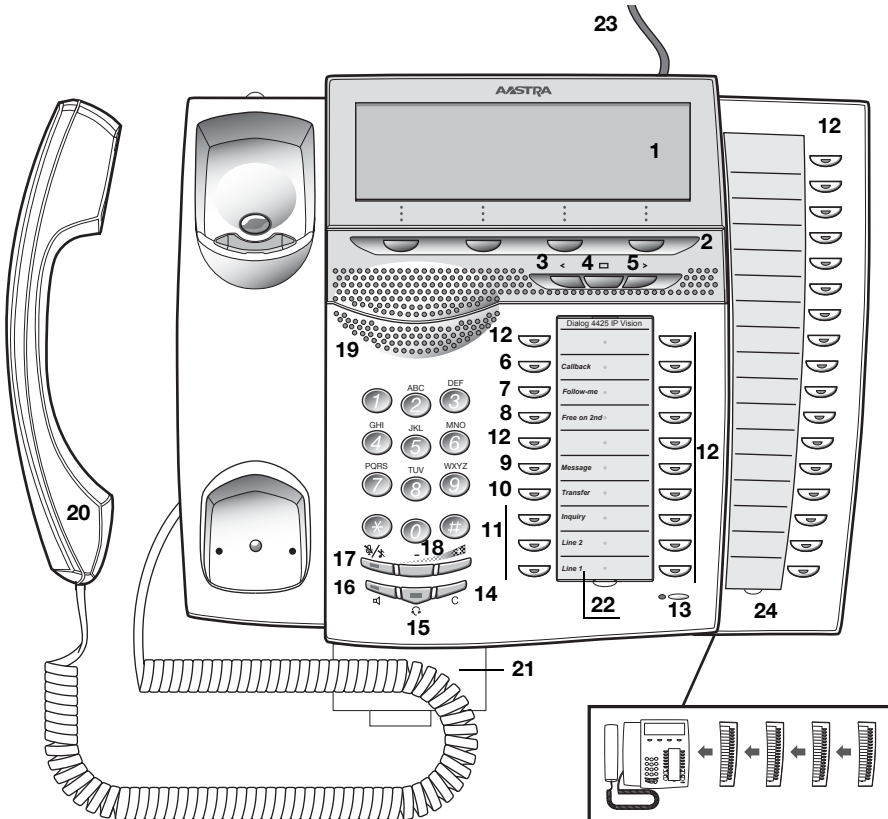
**1 Display**

See section “[Display information](#)” on page 14.

2 Display menu keys

The key functions depend on the traffic state. When you are requested “(see display)”, press the required key to access the feature.

3 Navigation key left

- a. Navigate one step to the left in the top menu. See section [“Display information”](#) on page 14.
- b. On WAP pages, this key is used to go to the previous page. See sections [“Corporate Directory”](#) on page 123, [“Web”](#) on page 125 and [“WAP Services”](#) on page 127.

4 Home

- a. Return to home position (idle mode). When this key is pressed, you always go to the home position, independent of which menu you are in. See section [“Display information”](#) on page 14.
- b. On WAP pages; if you press this key for a short while, you will return to the WAP home page. See sections [“Corporate Directory”](#) on page 123, [“Web”](#) on page 125 and [“WAP Services”](#) on page 127.

5 Navigation key right

Navigate one step to the right in the top menu. See section [“Display information”](#) on page 14.

Keys 6-10

Preprogrammed keys / Function keys / Monitoring keys

The keys are programmed with the specified default features (see below). The features can be moved to any other programmable function key by the system administrator.

The features can also be removed from the keys (by your system administrator). In this case you can program frequently used features and phone numbers on the keys.

The keys can also be used as Monitoring keys or for assigning the features Callback, Call Pick up, Call Waiting and Intrusion.

See sections [“Programming of function keys”](#) on page 93 and [“Key Monitoring”](#) on page 90.

6 Callback

Indicating/activating Callback. See section [“When you receive a busy tone”](#) on page 47.

7 Follow-me

Indicates an activated Follow-me. Also used to deactivate Follow-me. See section [“Call Forwarding”](#) on page 67.

8 Free on 2nd

Allow a second call to be received when you already have an active call. See section [“Answer a second call during an ongoing call”](#) on page 39.

9 Message

Message indication key. When the key lamp is lit, press the key to retrieve the message. See section [“Messages”](#) on page 80.

- 10 Transfer**
Transfer calls. See section [“Transfer”](#) on page 65.
- 11 Triple Access Line**
Handle calls. Line 1 and 2 are available both for incoming and outgoing calls. Inquiry can only be used for outgoing calls.
- 12 Programmable Function keys / Monitoring keys**
All keys, except for the Triple Access Line keys, can be used for programming, if programmed by your system administrator.
The keys can also be used for assigning the features Callback, Call Pick up, Call Waiting and Intrusion.
- Program phone numbers or features. See section [“Programming of function keys”](#) on page 93.
 - Monitor other extensions via a Monitoring key. See section [“Key Monitoring”](#) on page 90.
- 13 Microphone**
Used for handsfree conversation.
- 14 Clear**
Disconnect calls or exit a feature. Can always be pressed instead of replacing the handset.
- 15 Headset key**
Handle headset calls and activate Headset Preset. See section [“Headset \(optional\)”](#) on page 109.
- 16 Loudspeaker on/off**
The Speaker key is used for handsfree connection. By pressing and holding it down for 4 seconds, the loudspeaker preset mode is activated.
- Activate handsfree conversation. See section [“During Calls”](#) on page 62.
 - Activate Loudspeaker Preset. See section [“Headset Preset”](#) on page 110.
- 17 Mute**
- Switch the microphone on or off during a call. See section [“Mute”](#) on page 62.
 - Switch off the ring signal in idle mode or when ringing. See sections [“Mute ring signal”](#) on page 105 and [“Silent Ringing”](#) on page 105.
- 18 Volume control**
Adjust the volume. See section [“Settings”](#) on page 93.
- 19 Loudspeaker**

20 Handset

Supplied with hearing aid feature as standard.

Please note: *The handset can attract and trap small metal objects in the earcap region.*

21 Pull-out leaf for easy guide (optional)

See section “[Pull-out leaf \(optional\)](#)” on page 112.

22 Designation card

Use the DCM (Designation Card Manager) to make and print your own designation cards. DCM is included on the Enterprise Telephone Toolbox CD or it can be downloaded from:
<http://www.aastra.com>

For more information, please contact your Aastra Certified Sales Partner.

23 Power adapter connection

See section “[Start the Phone – Log On/Off](#)” on page 27.





24 Key panel

The extra key panel has 17 programmable keys. Up to four panels can be connected. See section “[Key panel](#)” on page 108. Use the Designation Card Manager to make and print your own key panel designation cards.

DCM is included on the Enterprise Telephone Toolbox CD or it can be downloaded from:
<http://www.aastra.com>

For more information, please contact your Aastra Certified Sales Partner.

Lamp indications

	Extinguished lamp	The feature is not active.
	Steady light	The feature is active or the multiple represented line is busy.
	Slowly flashing lamp	The line (or feature) is put on hold.
	Rapidly flashing lamp	An incoming call.
	Light with short breaks	Ongoing call.

Tones and signals

The following different tones and signals are sent from the telephone system to your phone.

Tone characteristics

The tones shown in this section are the most used tones worldwide. Many markets use a differing tone for one or more situations.

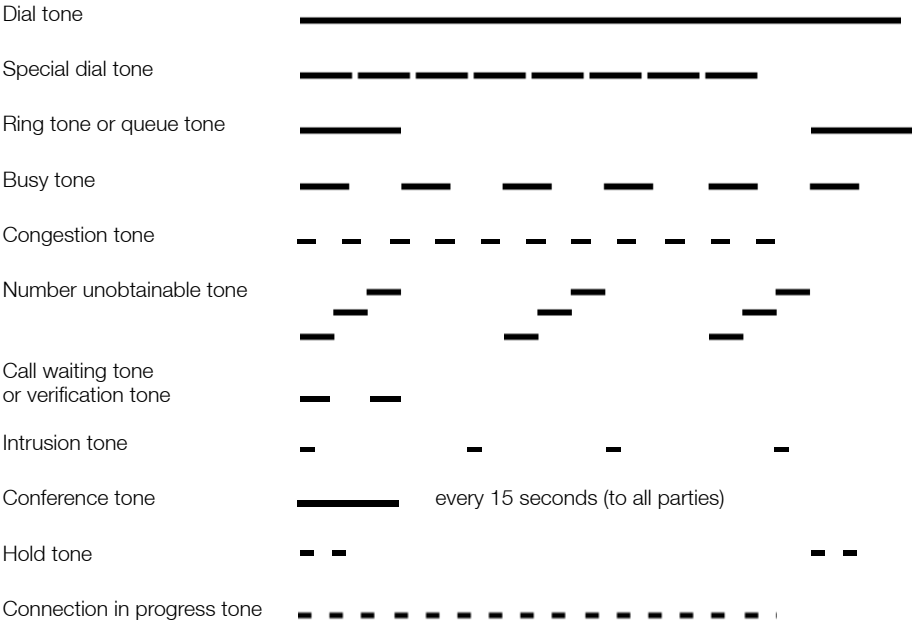

Ring signals

Three different ring signals inform you about the type of the incoming call. The signals shown in this section are the most used signals worldwide. Many markets use signals that are adapted for the local standards. If you get a signal that is not described or you cannot identify, ask your system administrator.

Internal ring signal



External ring signal



Recall signal
(Callback reminder)



The Monitoring keys can be programmed with other ring options, see section ["Change ring signal for a Monitoring key"](#) on page 106.

Display information

The display gives you feedback information such as time and date, traffic state and connected phone numbers. The following pages show examples of information displays from different telephone states.

Note: All names and numbers presented on the displays in this user guide are examples.

When an information ends with an exclamation mark (!), this means that no further action is possible.

Your phone has a graphical display which has approximately 6 rows with 50 characters each. However the number of rows and characters per row depend on the character size and the font. During log on, when the display shows a list, or when the phone is in a setting mode, the middle field of the display is adapted to fit each situation.

You can change the display menu language, the date/time presentation and display contrast level. For the Dialog 4425 v. 2 phone you can also change the display backlight level. See section “Settings” on page 93.

Two display versions

The display examples in this guide are valid for both the Dialog 4425 v. 2 phone and the Dialog 4425 v. 1 phone, however the displayed text simulates the Dialog 4425 v. 2 phone. If there is any information for the other version than the one described, this is presented in a “Telephone version note”. See example below.

Example of the Contacts menu and “Telephone version note”:

Settings	CallList	☐	Contacts	CorpDirectory	Web
Walter Matthau			0012115171		
Werner Smith			5555		
William Johnson			7777		
William Jones			7777		
Xerxes Anderson			3333		
Exit			Call		

Telephone version note: For the Dialog 4425 v. 1 phone select PhoneBook.

Top menu

The top menu is in the black frame below. The appearance of the top menu depends on which telephone version you are using (Dialog 4425 v. 1 phone or Dialog 4425 v. 2 phone), see examples below.

Dialog 4425 v. 1 phone:

Settings	CallList		PhoneBook	WAP Services
M Miller	>FollowMe			11:06 28 03 2008
B Brown	5555			J Smith 2222
CallBack				

Dialog 4425 v. 2 phone:

Settings	CallList		Contacts	CorpDirectory	Web
M Miller	>FollowMe				11:06 28 03 2008
B Brown	5555				J Smith 2222
CallBack					

The following main text and symbols can be shown on the display's top menu:

Settings

Access the Settings menu.

See section "[Settings](#)" on page 93.

CallList

Access the CallList menu.

See section "[Call List](#)" on page 52.



Home position (idle mode).

Contacts

Access the Contacts menu (Dialog 4425 v. 2 phone only).

See section "[Contacts \(PhoneBook\)](#)" on page 55.

PhoneBook

Access the PhoneBook menu (Dialog 4425 v. 1 phone only).

See section "[Contacts \(PhoneBook\)](#)" on page 55.

WAP Services

Access the WAP Services menu (Dialog 4425 v. 1 phone only).

See section "[WAP Services](#)" on page 127.

CorpDirectory

Access the CorpDirectory menu (Dialog 4425 v. 2 phone only).

See section "[Corporate Directory](#)" on page 123.

Web

Access the Web menu (Dialog 4425 v. 2 phone only).

See section "[Web](#)" on page 125.



Position indicator (selected top menu item).

Display symbols

Traffic status is indicated by the following symbols on the display:



> Follow-me indicator.

Indicates that the phone is forwarded to another extension. See section "[Call Forwarding](#)" on page 67.



Message.

Indicates that there is a message waiting. See section "[Messages](#)" on page 80.



Access warning.

Flashes when the access to system services is reduced (some system services does not work). See section "[Troubleshooting](#)" on page 141



Security

Indicates that the ongoing call is secure between the A and B party. The media (speech) and the signalling are encrypted.



Headset Preset

Indicates that the phone is set for incoming and outgoing calls to be connected to the headset when you answer or make calls without lifting the handset. See section "[Headset \(optional\)](#)" on page 109.



Ringer off (a) / Volume level bar (b).

Appears at the same position.

- a Indicates that the ring signal is switched off. See section "[Silent Ringing](#)" on page 105.
- b Indicates the ring signal volume in idle mode or ringing mode. In speech mode it indicates the loudspeaker volume, earpiece volume or headset volume. See section "[Settings](#)" on page 93.

The following symbols can be shown in the top menus or other display lists:

Example of the CallList menu:

Settings	CallList	Contacts	CorpDirectory	Web
	M Sadler	3333	12:24 28 03	
2	J Crichton	5555	11:33 28 03	
+	J Gilmour	5467	10:48 28 03	0:01:15
+		0012115171	15:11 27 03	0:15:11
+	S Negus	7777	14:06 27 03	0:06:53
more...				Call

Example of the Date Format menu:

Settings	CallList	Contacts	CorpDirectory	Web
Date Format				
	<input checked="" type="radio"/> 28 03 2008			
	<input type="radio"/> 28 Mar 2008			
	<input type="radio"/> Fr 28 Mar 2008			
	<input type="radio"/> 060328			
Cancel		Select		



or



New missed call(s).

Indicates new missed and not checked incoming call(s). The number beside the symbol indicates how many times this caller has tried to call you.



or



Missed call(s).

Indicates missed but checked incoming call(s). The number beside the symbol indicates how many times this caller has tried to call you.



Incoming call.

Indicates an answered incoming call.



Outgoing call.

Indicates an outgoing call.



Bar indicator.

Indicates the shown part of the total list and where it is positioned in the total list.

15 03 2008

Selection frame.

Indicates the subject to be called or selected in the list.



Setting indicators.

Filled symbol indicates the current setting in the shown list.



Up.

Scroll up or to the left in the menu.



Down.

Scroll down or to the right in the menu.

Idle phone (idle mode)

When your phone is in idle mode, the display shows the top menu. Below the top menu; time, date, name your extension number are shown to the right. Below the line, lead text for the display menu keys is shown. In the example below, the extension number for *J Smith* is 2222.

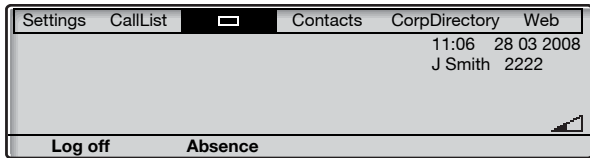

Note: *When the name and extension number are long, the name is shown on one row and the number on another row.*

Unanswered phone calls are indicated on the idle phone display.

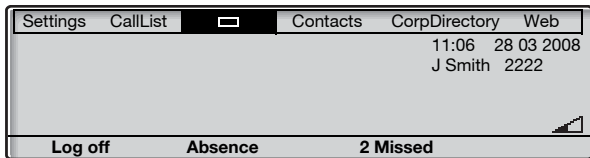

An activated Follow-me is also indicated in the idle phone display.

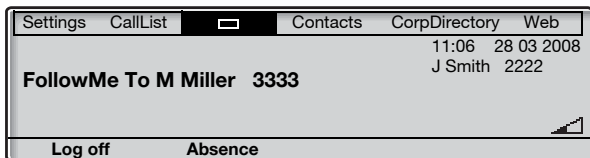

Smith (2222) has activated a Follow-me to Miller (3333).

Outgoing call

Except for the idle information in the top menu, the display also shows the dialed name (if available) and number.



When the dialed number is busy, the display will look like this.

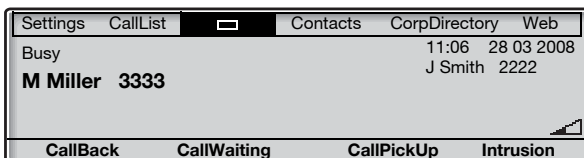

If the called party's phone is diverted, the Follow-me information and the answering extension name and number are shown below the top menu. > is the Follow-me symbol.



The call to Miller (3333) is directly diverted to Brown (5555).

Incoming call

Except for the idle information in the top menu, the display also shows the calling party's name (if available) and number. The name and number are flashing. If the number for an external call is not available, the display shows **External** instead of the number.

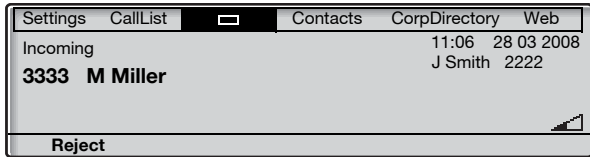

If a diverting extension is calling, the Follow-me information and the calling party's name and number (flashing) are shown below the top menu. > is the Follow-me symbol.

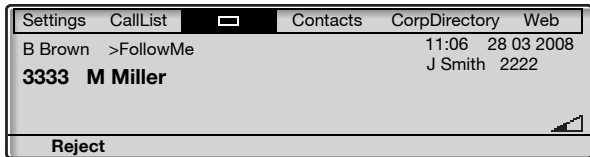



Miller (3333) has called Brown and the call is directly diverted to you.

Display menu keys

The display menu keys are used to access different functions. The available functions vary depending on the traffic state and category of the extension. The following key text and abbreviations are used for the display menu keys.

Note: *If you have an earlier version of the telephone system, some text for the display menu keys might be different or not available.*

Menu key	Function
- (minus)	Decrease contrast level on the display
+ (plus)	Increase contrast level on the display
	Scroll up
	Scroll down
Absence	Handle Absence and Call Forwarding
(No change)	Keep current IP settings
Account	Account Code
AddContact	Add to Contacts (Dialog 4425 v. 2 phone only)
AddPhoneBook	Add to PhoneBook (Dialog 4425 v. 1 phone only)
Back	Return to previous menu
Call	Call the number displayed
CallBack	Callback
CallPickUp	Call pick-up
CallWaiting	Call waiting
Cancel	Leave a menu without change
Change	Change a setting (toggling two modes)
ChangeUser	Personal log on (for example Free Seating). Might be disabled in some systems.
Conf/Transf	To get a new line for conference or transfer
Conference	Connect a conference member
Deactivate	Deactivate Follow-me
Delete	Delete an item
Edit	Change property of item

Menu key	Function
Erase	Remove last character from display
Exit	Exit the displayed menu
GrpPickUp	Group call pick-up
Hold	Put the call on hold
Intrusion	Intrusion
Log off	Log off from the system
Log on	Log on to the system
n Missed	Number of missed calls in the call history list
Name	Edit name in Contacts (PhoneBook)
No	Negative answer
No Profile	Cancel activated search profile
Number	Edit number in Contacts (PhoneBook)
more...	More menu choices
OK	Answer OK to a question
Options	Show optional menus
Reject	Reject an incoming call
Save	Save settings
Search	Search Contacts (PhoneBook)
Select	Select item in a list
Stop	Stop fetching WAP page
Yes	Positive answer

Menu structure Dialog 4425 v. 1 phone

Menu structure for each of the menus that can be selected from the idle menu. When you are navigating the menus, a selected menu is marked with a black frame. Use the navigation keys and the display menu keys to navigate in the menus.

Top menu

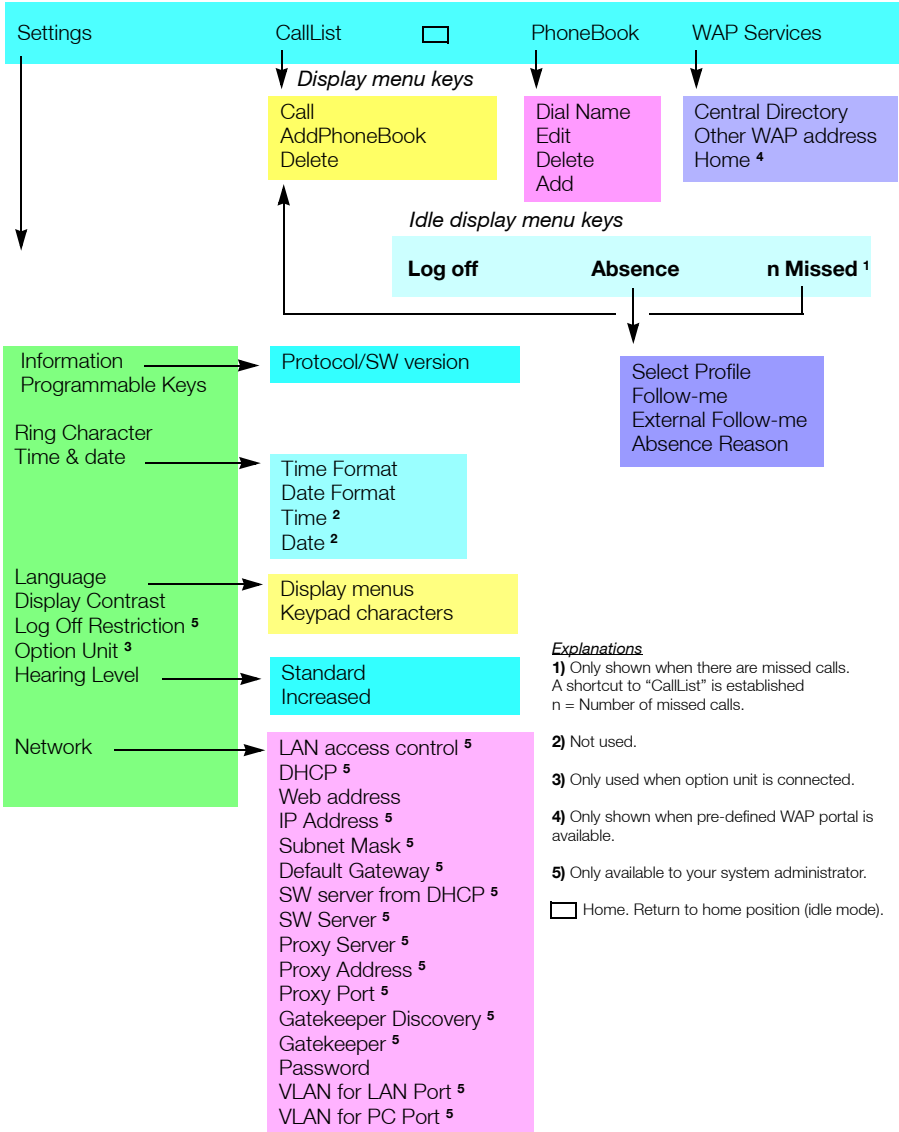

Menu structure Dialog 4425 v. 2 phone

Menu structure for each of the menus that can be selected from the idle menu. When you are navigating the menus, a selected menu is marked with a black frame. Use the navigation keys and the display menu keys to navigate in the menus.

Top menu

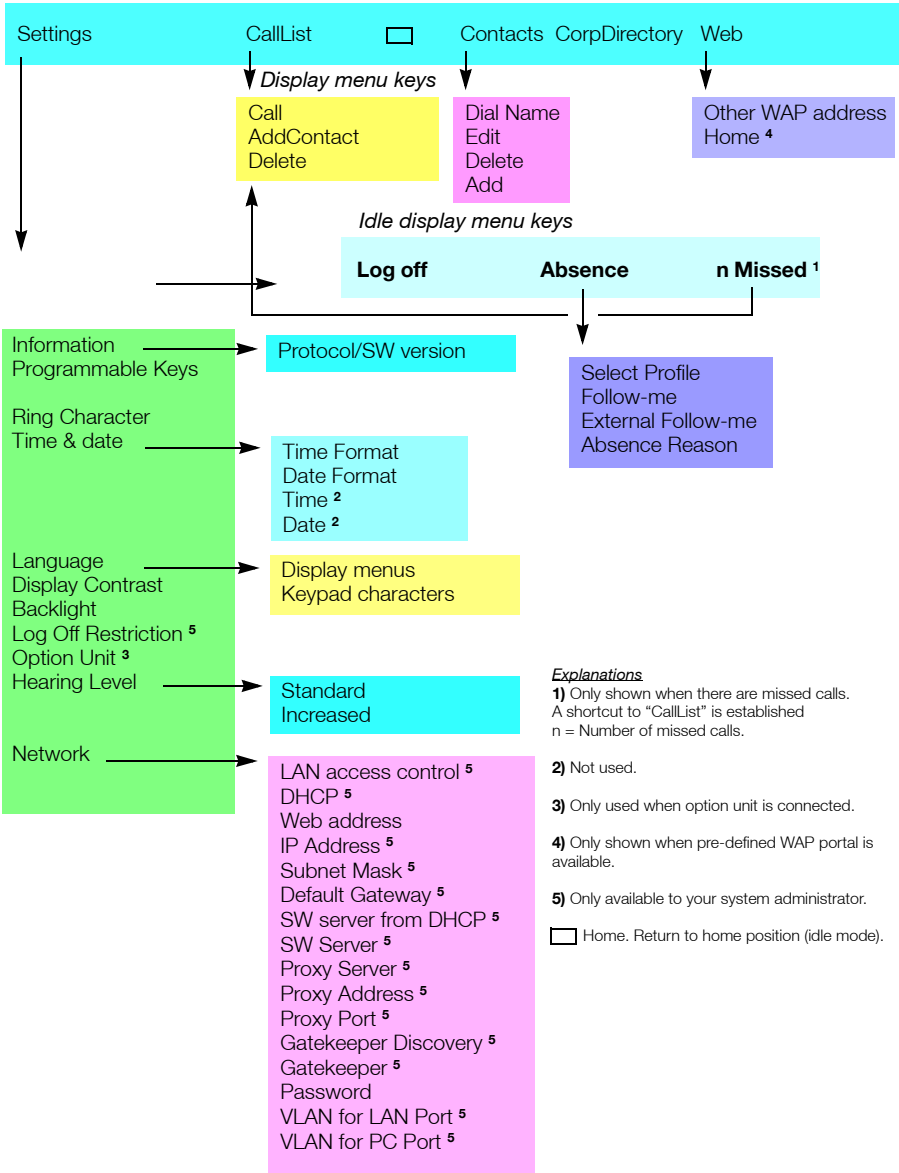

Start the Phone – Log On/Off

Startup procedure

All the system settings for your IP phone must be set by the system administrator before you can use the phone.

Connect the required cables.

See section “[Installation](#)” on page 132.

Note: *Depending on the settings in your network and telephone system, the start up procedure may be different from phone to phone. Check the display on your phone and read the required sections in this chapter to continue with the start up procedure.*

When the phone is connected to the network, your phone automatically initiates the startup procedure when connected to the mains.

Notes:

The phone does not work when a power failure occurs. After a power failure the phone will automatically restart. After a power failure the Call List is cleared.

When the telephone is starting up (booting) a connected PC will loose it's network connection for about 10 seconds.

LAN access control (network authentication)

(Dialog 4425 v. 2 phone only).

Your telephone might require a network authentication to gain access to the network. In this case you must enter a valid user identity and PIN or password.

Note: *The user identity and password used for the network authentication is not the same user identity and password you use to log on. The password is obtained from, and can only be changed by the system administrator.*

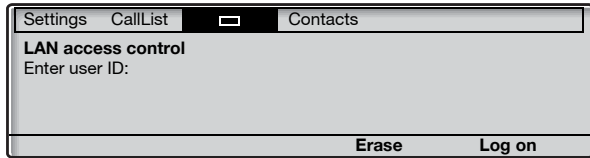

Enter your user identity.

(The display menu key **Erase**, is used to remove a wrong entry.)

Log on



Press (see display).

Enter your PIN or password.

(The display menu key **Erase**, is used to remove a wrong entry.)

Note:

The password can be entered with letters or numbers, see section [“Entering names and numbers”](#) on page 56.

The PIN is the same as the Individual Authorization Code. Only digits can be used as PIN. The PIN must be four digits or more.

Log on

Press (see display).

If your user identity and password are accepted, the phone continues with the startup procedure.

Note: *If your user identity and password are not accepted, contact your system administrator.*

Continued startup procedure

The display shows:

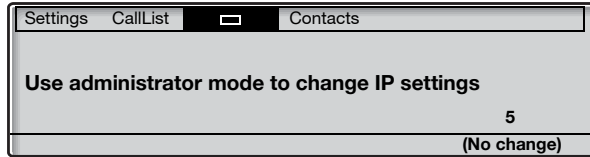

A timer counts down from 5 seconds. If no key is pressed during this time, **(No change)** is selected automatically.

Notes:

You can speed up the procedure by pressing

(No change).

The administrator mode is used to change the IP settings in your phone. This mode is reserved for your system administrator.

The display now indicates that the phone is connecting to the server and the software is loading. This takes about 1 minute. After a self test, the phone is ready for use or ready for log on. To log on, see section "[Log on](#)" on page 31.

Update software

If new software has to be loaded into your phone, the display is showing this. When new application software is available, the following display is shown:

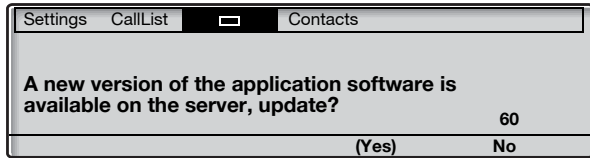

A timer counts down from 60 seconds. If no key is pressed during this time, **(Yes)** is selected automatically.

Note: *You can speed up the procedure by pressing **No**.*

(Yes)

Press to update the software (see display).

The software is loaded from the server. This takes about 60 seconds. The phone is then ready for use or ready for log on. To log on, see section “[Log on](#)” on page 31.

Note: *It is important that you do not disconnect the power to the phone while the new software is being downloaded and saved. If a power failure occurs, the software must be downloaded again.*

If you want to continue to use the previously stored setting:

No

Press to use the current version of the software (see display).

Log on

If your phone requires a log on, there are three log on options:

- 1 You are allowed to log on and log off the phone. This is the most common option.
- 2 The telephone is always logged on with a default number. You cannot log on or off. This option can be used for phones in conference rooms, receptions and so on.
- 3 The telephone is always logged on, with a default number, as in option 2, but you can log on with your own extension number and get your personal categories. This option can be used in a Free Seating environment. See also section “[Free Seating](#)” on page 35.

Option 1

The log on menu is displayed:

Settings	CallList	<input type="checkbox"/>	Contacts	CorpDirectory	Web
User not logged on!				11:06	28 03 2008
Log on with: 2222					
For SOS calls, dial 112					
				Erase	Log on

If the SOS call feature is disabled, the text **For SOS calls, dial 112** is not shown. The number for SOS calls might vary between countries. See section “[SOS calls \(Emergency calls\)](#)” on page 43.

The extension number that was used for the last log on is automatically shown.

If the displayed number is your number:

Log on

Press to log on (see display).

The display shows:

Settings	CallList	<input type="checkbox"/>	Contacts	CorpDirectory	Web
				11:06	28 03 2008
				J Smith	2222
				Log off	Absence



If the displayed number is not yours (the telephone has been logged on by another person):

Dial your extension number.

The displayed number is automatically erased when you start dialing. The display shows your entered digits. (The display menu key **Erase**, is used to remove a wrong entry.)

Log on

Press to log on (see display).

If a PIN or password is not required, the display shows your name and extension number, and the phone is ready for use.

If a PIN or password is required the display shows:

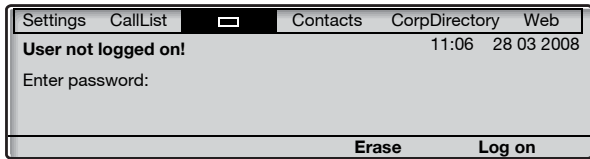

Notes:

The last setting used (by previous user) remains until changed. The request to enter a password can be changed, contact your system administrator.

The password is obtained from, and can only be changed by the system administrator.

The PIN is the same as the Individual Authorization Code. Only digits can be used as PIN. The PIN must be four digits or more.



Enter your PIN or password.

(The display menu key **Erase**, is used to remove a wrong entry.)

Telephone version note: *For Dialog 4425 v. 2 phone the password can be entered with letters or numbers, see section "Entering names and numbers" on page 56.*

Log on

Press to log on (see display).

The display shows your name and extension number, and the phone is ready for use.

Option 2

The following idle mode menu is displayed, and the phone is ready for use.

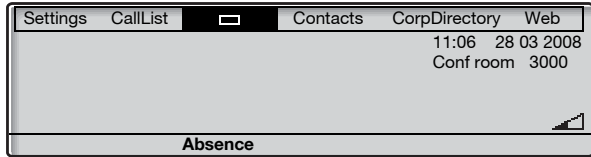

Note: It is not possible to log off, when a phone has been programmed according to this option.

Option 3

The following idle mode menu is displayed. You can log on with your own extension number and get your personal categories.

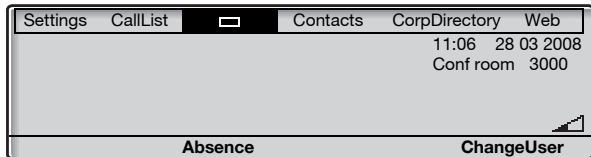

ChangeUser



Log on



Press (see display).

Dial your extension number.

Press to log on (see display).

If a PIN or password is not required, the display shows your name and extension number, and the phone is ready for use.

If a PIN or password is required:

Enter your PIN or password.

Telephone version note: For Dialog 4425 v. 2 phone the password can be entered with letters or numbers, see section [“Entering names and numbers”](#) on page 56.

Note: The PIN is the same as the Individual Authorization Code. Only digits can be used as PIN. The PIN must be four digits or more.

Log on

Press to log on (see display).

The display shows your name and extension number, and the phone is ready for use.

Note: *During the night, the phone is automatically logged off, and then logged on again with the default number.*

Log off

Log off

Press to log off (see display).

The text **Log off?** is displayed.

Yes

Press to confirm (see display).

- If your phone has been programmed according to option 1, the log on menu is displayed.
- If your phone has been programmed according to option 3, the following idle mode menu is displayed.

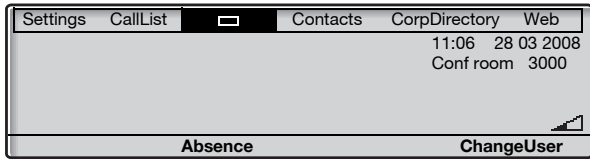

Note: *If your phone has been programmed according to option 2, it is not possible to log off.*

Reset the phone

If your phone does not work properly, you can use the following procedure to reset the phone. This procedure will also clear the Call List. After the procedure you must log on again to use the phone.



Press all three keys simultaneously for at least one second to reset the phone.

Free Seating

As you can log on to any IP phone in the network by using your extension number, every IP phone automatically works as a free seating telephone within the network. See also option 3 in section “[Log on](#)” on page 31.

Note: *Using the Free Seating feature by entering *11* Authorization Code * extension No. #, is not applicable.*

Incoming Calls

Answer calls

A ring signal and a flashing lamp indicate an incoming call.

Note: *If the feature Parallel Ringing is activated, the call will ring on more than one phone, see section “Parallel Ringing” on page 40.*

On Line 1

Normally you will receive calls on Line 1.



Lift the handset.

On Line 2 or Monitoring key

Lift the handset.



Line 2

Press the flashing Line 2 key,

If you have an ongoing call (Line 1), the first call is put on hold.

or



Jim

Press the flashing Monitoring key.

If you have an ongoing call (Line 1), the first call is put on hold.

Notes:

If a tone is heard, wait for the tone to stop before starting the conversation.

You can change the ring signal for the Monitoring key, see section “Change ring signal for a Monitoring key” on page 106.



Line

Handsfree

Press the flashing Line key,

or



Jim

Press the flashing Monitoring key.

Note: You can change the ring signal for the Monitoring key, see section [“Change ring signal for a Monitoring key”](#) on page 106.

You are connected to the caller via the loudspeaker and the microphone.



Press to terminate a handsfree call.

On another extension

You can answer a call to another extension:



Call the ringing extension.

Busy tone.

Settings	CallList	<input type="checkbox"/>	Contacts	CorpDirectory	Web
Busy			11:06	28 03 2008	
M Miller 3333			J Smith	2222	
CallBack		CallWaiting		CallPickUp	Intrusion

CallPickUp

Press to answer (see display).

Automatic Answer

The automatic answer feature means that incoming calls are answered automatically in handsfree mode, without anyone having to pick up the handset.

The automatic answer feature is enabled by the system administrator, who can select one of the following two answering options:

- With delay: Speech connection is established in handsfree mode after one ring signal.

- No delay: Speech connection is established directly in handsfree mode.

Check if automatic answer is enabled:



Select Settings in the top menu (see display).



Press (see display).

Repeat until the **Auto Answer** menu is framed.

Select

Press (see display).

The current setting is framed.

Cancel

Press to return to the previous menu (see display),

or



press to return to idle mode.

Answer a second call during an ongoing call

You can receive another call, when Free on 2nd is activated.



Press to activate/deactivate.

When Free on 2nd access is active the lamp is lit.

When you have an ongoing call on Line 1, and Line 2 flashes to indicate a new incoming call:



Press to answer.

The first call is put on hold.



Press to switch back to the first call.

The second call is put on hold. You are connected to the first caller.



Press to terminate the connected call.

Call Waiting

If the calling party has activated Call Waiting, you can receive a second call even if Free on 2nd is not activated.

To answer the waiting call:



Press to terminate the connected call.

Your phone will ring to announce the waiting call.



Press the flashing Line key to receive the new call.

Parallel Ringing

The Parallel Ringing feature makes it possible for an incoming call to ring several phones simultaneously and for the call to be answered on any of the phones. The main advantage of this feature is that you do not risk losing any calls.

The feature requires all the phones involved to be defined in a **Parallel Ringing list**, which must be configured and initiated by your system administrator. Because only calls to a main extension will be distributed among the phones in the list, this main extension also needs to be defined.

A call to a specific extension will not be distributed to other phones in the list, and will only ring that specific extension's phone.

Parallel Ringing can be temporarily disabled by the phone user using the feature "Internal Follow-me". See also section "[Internal Follow-me](#)" on page 67.

Note:

If an extension part of a parallel ringing list tries to activate/deactivate one of the features below, the procedure is only performed on the main directory number not on the extensions own number.

- Call diversion for non-generic extension
- Do not disturb
- External Follow-me
- Follow-me
- General Cancellation
- Individual Repeated Distribution or Personal Number
- Message Diversion

To disable Parallel Ringing temporarily

Absence



Press (see display).

Press (see display).

Repeat until the **Follow-me** menu is framed.

Select



Press (see display).

Enter the extension number.

If you want to disable Parallel Ringing for all phones defined in the list, follow the procedure for disabling the feature from the phone with the main extension number and enter the number of the answering position.

If you want to disable Parallel Ringing for one specific phone in the list only, follow the procedure for disabling the feature from this phone and enter its extension number.

Notes:

*You can also use the following procedure to disable: dial *21* (U.K. *2*), dial the extension number of the phone, press # and press the Clear key.*

The Follow-me key cannot be used to disable Parallel Ringing.

OK

Press (see display).

The Follow-me key lamp is now on.

To restore Parallel Ringing



Follow-me

Press.

The Follow-me key lamp is off.

Notes:

You can also use the following procedure to restore: dial #21# (U.K. #2#) and press the Clear key.

If you want to restore Parallel Ringing for all phones defined in the list, follow the procedure for restoring the feature from the phone with the main extension number and enter the number of the answering position.

If you want to restore Parallel Ringing for one specific phone in the list only, follow the procedure for restoring the feature from this phone and enter its extension number.

Outgoing Calls

Make calls

Note: You can dial your calls faster by using common Speed Dialing numbers and by using your own programmed function keys or preprogrammed Monitoring keys. See section “Speed Dialing” on page 49.



How to make internal and external calls:

Lift the handset and proceed depending on call type:

Internal calls



Dial the extension number.

External calls

0 **Dial the digit or digits to get an external line.**

Dial tone.

Note: The particular digit or digits used in your office, for example **0** or **00**.



Dial the external number.

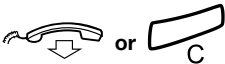

Replace the handset or press to end the call.

Handsfree

With the handset on hook:



Dial the number.

You are connected via the loudspeaker and microphone.



Press to terminate a handsfree call.

SOS calls (Emergency calls)

When your phone is logged on



Dial the SOS number.

When your phone is logged off

The log on menu, with the text **For SOS calls, dial 112** is displayed:

Settings	CallList		Contacts	CorpDirectory	Web
User not logged on!				11:06	28 03 2008
Log on with: 2222					
For SOS calls, dial 112					
				Erase	Log on



Dial the SOS number.

Your phone is automatically logged on to make the SOS call.

Notes:

*If the message **For SOS calls, dial 112** is not shown on the log on display, you have to log on before you can make SOS calls.*

The number for SOS calls might vary between countries.

* 0 *  #



Individual External Line

To make a call on a specific external line:

Dial, enter the Individual External Line number and press.

Dial the digit or digits to get an external line and the external number.



* * *

Last External Number Redial

When you initiate an external call the system automatically stores all the dialed digits, irrespective of whether the call was successful or not.

Lift the handset.

Dial to repeat the stored number.

The last external number is automatically redialed.

Note: *Finland and Sweden, dial * * 0*

Redial calls from the Call List

To use the Call List, see section “[Call List](#)” on page 52.



Select CallList in the top menu (see display),

The display shows:

Settings	CallList	Contacts	CorpDirectory	Web
2	M Sadler	3333	12:24 28 03	
2	J Crichton	5555	11:33 28 03	
	J Gilmour	5467	10:48 28 03	0:01:15
		0012115171	15:11 27 03	0:15:11
	S Negus	7777	14:06 27 03	0:06:53
more...				Call

or

n Missed

press (see display).

n = Number of missed calls.

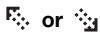

Call

Press to frame a phone number (see display).

Press to call the framed phone number (see display).

Note: To add the number to **Contacts (PhoneBook)**, see section “[Add number from the Call List](#)” on page 61.

Number Presentation Restriction

If you do not want your name and number to be displayed to the person you are calling, use the following procedure.

Note: *The Number Presentation Restriction is only valid for the ongoing call, that is the procedure has to be repeated the next time you want to use it.*

***42#**

Dial and wait for a new dial tone.



Dial the number.

Instead of your name and number, the display on the called phone shows **Anonymous**.

When you receive a busy tone

If you call an extension and receive a busy tone, or get no answer, or all external lines are busy, you can use any of the following methods:

Callback

If a called extension is busy or there is no answer:

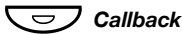

Callback

Press.

It can take several seconds before the procedure is executed. A confirmation tone is heard.

Note: *You can also press: **CALLBACK** (see display).*



Replace the handset to finish the procedure.

You are called back (recall ring signal) when the ongoing call is finished or the next time a new call is finished. You have to answer within eight seconds, otherwise the Callback service is cancelled. While waiting for the Callback, you can make and receive calls as usual.



Lift the handset when you are called back.

The system calls the extension.

Note: *Callbacks can be activated on several extensions at the same time.*

If all external lines are busy (after dialing the digit or digits to get a line):



Callback

Press.

Note: *You can also press: **CALLBACK** (see display).*



Dial the external number and press.



Replace the handset to finish the procedure.

When an external line becomes free you will be called back (recall ring signal). You have to answer within eight seconds, otherwise the Callback service is cancelled. While waiting for the Callback, you can make and receive calls as usual.



Lift the handset when you are called back.

The system calls the external number.

Note: *Only one Callback can be activated on a busy external line.*

3 7 * 



Cancel any single Callback

Dial, enter the extension number and press.

Note: To cancel a single Callback on a specific external line, dial the digit or digits to get a line instead of the extension number.

Press.

3 7



Cancel all Callbacks

Dial.

Press.

Activate Call Waiting

If you urgently wish to contact a busy extension or external line, you can notify by a Call Waiting signal.

CallWaiting

Press (see display).

Keep handset off hook. When the called extension or the external line becomes free, it will be called automatically.

Note: The Call Waiting feature might be blocked for use on your extension (programmed by your system administrator). If Call Waiting is not allowed you will continue to receive a busy tone.

Intrusion on a busy extension

You can intrude on an ongoing call on a busy extension.

Intrusion

Press (see display).

Before the intrusion is executed a warning tone is sent to the parties in the ongoing call. A three party call is established and a warning tone is heard.

Note: The warning tone might be disabled for your system. The Intrusion feature might be blocked for use on your extension (programmed by your system administrator). If Intrusion is not allowed, you will continue to receive a busy tone.

When you receive an absence message

When you call an extension that has message diversion active, the absence reason appears on the display of your phone.



MoreInfo

Dial the extension number (for example, 1234).

The absence reason appears in the display of your phone.

Press (see display).

The call is diverted. If you do nothing, the call is terminated after a timeout.

Note: You can also divert the call by pressing *.

Bypass

If this feature is allowed from your extension, you can bypass an activated Diversion, activated Follow-me or activated Absence Information on a specific extension.

✳ 60 ✳  #

Dial, enter the extension number and press.

Wait for answer.

Speed Dialing

Common Speed Dialing Numbers

By using common Speed Dialing numbers, you can make calls simply by pressing a few keys. The common Speed Dialing numbers consist of 1–5 digits and are stored in the telephone system (by your system administrator).



Lift the handset and dial the common Speed Dialing number.

Dial by a function key

Both features and phone numbers can be programmed on a function key. To program a key, see section “[Programming of function keys](#)” on page 93.

Head office



Press the function key.

This function key is programmed by you.

Dial by a Monitoring key

The extension that is monitored can be called by pressing this key.



Jim

Press the Monitoring key.

This key is preprogrammed by your system administrator.

Dial by Contacts (PhoneBook)

With this feature you can make a call using the contacts stored in your phone.

Example: To find and call Zeb Macahan

In idle mode:

9 Press and hold the key.

The available names for that key are shown on the display.

Settings	CallList	Contacts	CorpDirectory	Web
Walter Matthau				0012115171
Werner Smith				5555
William Johnson				7777
William Jones				7777
Xerxes Anderson				3333
Exit				Call

9 Press three times to jump to the first name beginning with the letter "Z".

Settings	CallList	Contacts	CorpDirectory	Web
Zeb Cruise				0013315242
Zeb Ford				8888
Zeb Macahan				0015477816
Zeb Norris				9999
Zeb Smith				0017524819
Exit				Call



Press two times to scroll to Zeb Macahan (see display).

Call Press to make the call (see display).

Note: To learn more about how to handle **Contacts (PhoneBook)**, see section "[Contacts \(PhoneBook\)](#)" on page 55.

Call List

The phone stores a Call List with 50 phone numbers that includes missed calls (if supported by the network), incoming calls, outgoing calls and answered calls.

Note: *The list is cleared if a power failure occurs, if another user (extension number) logs on to the same phone or if you reset the phone.*



To access the Call List

Select CallList in the top menu (see display),

The Call List is displayed, see example.



or

n Missed







press (see display).

n = Number of missed calls.

Display menu key options

-  or  **Press to frame a phone number in the list (see display).**
- Call** **Press to call the framed phone number (see display).**
See section “[Redial calls from the Call List](#)” on page 45.
- more...** **Press to access more options (see display).**
- Exit** **Press to exit the CallList menu (see display).**
- Back** **Press to return to the previous menu (see display).**
- Delete** **Press to delete the framed call (see display).**
- AddContact** **Press to add the framed phone number to Contacts (see display), (Dialog 4425 v. 2 phone only).**
See section “[Add number from the Call List](#)” on page 61.
- AddPhoneBook** **Press to add the framed phone number to PhoneBook (see display), (Dialog 4425 v. 1 phone only).**
See section “[Add number from the Call List](#)” on page 61.

Example of the CallList menu:

Settings	CallList	Contacts	CorpDirectory	Web
 2	M Sadler	3333	12:24 28 03	
 2	J Crichton	5555	11:33 28 03	
 ←	J Gilmour	5467	10:48 28 03	0:01:15
 →		0012115171	15:11 27 03	0:15:11
 →	S Negus	7777	14:06 27 03	0:06:53
more...				Call

The content of the Call List is (from left to right):

- Call symbol. See call symbol types below.
- Name of the calling/called person, for example “J Gilmour”.
- Phone number of the calling/called person, for example “5467”.
- Time of the call, for example “10:48”.
- Date of the call (Day/Month or Month/Day depending on date format setting), for example “28 03”.
- Call duration, for example “0:01:15”. (= one minute and 15 seconds).
- Bar indicator. Indicates the shown part of the total list, and where that part is positioned in the total list.

Call symbols types:

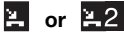

New missed call(s).

Indicates new missed and not checked incoming call(s). The number beside the symbol indicates how many times this caller has tried to call you.



Missed call(s).

Indicates missed but checked incoming call(s). The number beside the symbol indicates how many times this caller has tried to call you.



Incoming call.

Indicates an answered incoming call.



Outgoing call.

Indicates an outgoing call.

Contacts (PhoneBook)

You can store your most frequently used numbers in **Contacts (PhoneBook)** locally in your phone.

Settings	CallList	Contacts	CorpDirectory	Web
Walter Matthau				0012115171
Werner Smith				5555
William Johnson				7777
William Jones				7777
Xerxes Anderson				3333
Exit				Call

Telephone version note: *For the Dialog 4425 v. 1 phone select PhoneBook.*

There are a number of ways to add numbers and names into your phone:

- 1 Enter the name and number by using the digits 0-9 on the keypad, in the same way as with a mobile phone.**
- 2 Add an incoming call from the Call List into Contacts (PhoneBook).**
- 3 From a PC browse into the phone using a standard web browser and enter the name and number.**
See section "[Web Server](#)" on page 115.
- 4 From the PC application "My Dialog 4000 Contacts" you can add your Microsoft® Outlook® contacts to Contacts in your phone (Dialog 4425 v. 2 phone only).**
See section "[Add Microsoft Outlook Contacts](#)" on page 113.

To make a call via **Contacts (PhoneBook)**, see section "[Dial by Contacts \(PhoneBook\)](#)" on page 51.

Entering names and numbers

You can see the most common letters above each key on the phone. To get the letter A press key 2 once, for B press key 2 twice, to get C press key 2 three times, and so on. It is also possible to get other characters, see section “[Character map](#)” on page 57.

Note: *If the word to enter contains a digit, the digit can be created by pressing the digit key for more than 1 second.*

By default, the first character you enter is written in upper case, and the rest of the word is written in lower case. Every new word starts with an upper case character (that is after a space has been entered). However, you can force the phone to enter all characters as upper case only, or lower case only, see below.



Press to switch between upper and lower case.

All entered characters are entered as upper or lower case. This is only valid for the characters A-Z.



Press to correct a wrong entry (see display).

If you want to try writing text, you can use the example below.

Example: To enter the name Smith

7777

Press for S

The marked character is selected after a time out or when another key is pressed.

6

Press for m

4 4 4

Press for i

8

Press for t

4 4

Press for h



Press to return to idle mode.

For the Dialog 4425 v. 2 phone, a square is shown around the available characters. If you for example press **9**, the following character options are shown on the display:

wxyz9

Press 9

A new character (w, x, y, z or 9) is selected each time you press the key.

Character map

Default character map of all available characters in upper case.

Phone key	Number of times to press the key																		
	1	2	3	4	5	6	7	8	9	10	11	12	13	14	15	16	17	18	19
1	Space	-	?	!	,	.	:	;	"	'	()	1						
2	A	B	C	Å	Ä	Æ	À	Ç	2	Γ									
3	D	E	F	È	É	3	Δ	Φ											
4	G	H	I	Ì	4														
5	J	K	L	5	Λ														
6	M	N	O	Ñ	Ö	Ø	Ò	6											
7	P	Q	R	S	ß	7	π	Σ											
8	T	U	V	Ü	Ù	8													
9	W	X	Y	Z	9														
0	+	&	@	/	□	%	\$	€	£	¥	\	\$	¿	¡	0	Θ	Ξ	Ψ	Ω
#	#	*	<	=	>	_	μ		[]	{	}							

Notes:

You can switch to another character map (if programmed in the telephone system), for example to Greek or Cyrillic, which means that the character order can differ from the table above. See section [“Change keypad character map”](#) on page 97.

In lower case mode some characters are not the same as in upper case mode.

Add name or number

If you want to add the name and number from the Call List, see section “[Redial calls from the Call List](#)” on page 45.



Select Contacts in the top menu (see display).

Telephone version note: *For the Dialog 4425 v. 1 phone select PhoneBook.*

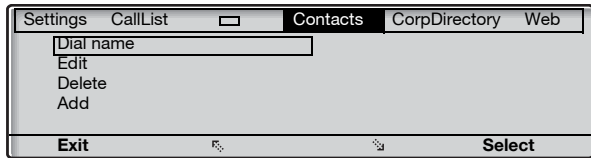

Press (see display).

Repeat until the **Add** menu is framed.

Select

Press (see display).

Enter name: is prompted.



Enter the name.

Save

Press (see display).

Enter number: is prompted.



Enter the associated number.

Save

Press (see display).

The programmed name and number are shown on the display.

Note: *If a character is wrong, press the **Edit** key to correct the entry.*

OK

Press to confirm (see display).

Exit

Press to return to the previous menu (see display),

or



press to return to idle mode.

Edit name or number

To change something in the name or number for an entry:



Select Contacts in the top menu (see display).

Telephone version note: *For the Dialog 4425 v. 1 phone select PhoneBook.*



Press (see display).

Repeat until the **Edit** menu is framed.

Select

Press (see display).

Enter name: is prompted.



Search

Enter the first letters of the name and press (see display).



Scroll until you find and frame the name (see display).

Edit

Press (see display).

Erase

Press (see display).

Repeat until the position for editing is reached, or until the complete name is erased.



Enter the remaining characters or the new name.

Save

Press to save the name (see display),

The changed name and number are shown on the display.

or

Number

press to change the number (see display).

Enter number: is prompted.

Erase

Press (see display).

Repeat until the position for editing is reached, or until the complete number is erased.



Enter the remaining characters or the new number.

Save **Press to save the number (see display).**
The changed name and number are shown on the display.

*Note: If a character is wrong, press the **Edit** key to correct the entry.*

OK **Press to confirm (see display).**

Exit **Press to return to the previous menu (see display),**

or



press to return to idle mode.

Delete name or number



Select Contacts in the top menu (see display).

Telephone version note: For the Dialog 4425 v. 1 phone select PhoneBook.



Press (see display).

Repeat until the **Delete** menu is framed.

Select

Press (see display).

Enter name: is prompted.



Enter the first letters of the name.

Search

Press (see display).



Scroll until you find and frame the name (see display).

Delete

Press to delete a found entry (see display).

*Note: The **Cancel** key can be used if you change your mind and want to keep the entry.*

OK **Press to confirm (see display).**

Exit **Press to return to the previous menu (see display),**

or



press to return to idle mode.

Add number from the Call List

You can add numbers in the Call List to **Contacts (PhoneBook)**.

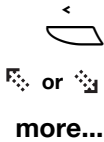

Select CallList in the top menu (see display).

Press to frame a phone number (see display).

Press (see display).

The display shows:

Settings	CallList	Contacts	CorpDirectory	Web
2	M Sadler	3333	12:24 28 03	
2	J Crichton	5555	11:33 28 03	
	J Gilmour	5467	10:48 28 03	0:01:15
		0012115171	15:11 27 03	0:15:11
	S Negus	7777	14:06 27 03	0:06:53
	Exit	Back	Delete	AddContact

AddContact

Press to add the framed phone number to Contacts (PhoneBook) (see display).

Telephone version note: For the Dialog 4425 v. 1 phone select AddPhoneBook.

Edit

Press if you want to add a name or change the number (see display),

or

OK

press to confirm (see display).



Press to return to idle mode.

Note: To use the Call List, see section *“Call List”* on page 52.

During Calls



Handsfree

Press.
Handsfree conversation.

Press to end the call.

From handsfree to handset

If the handset is on hook:



Lift the handset.
Conversation via the handset.

If the handset is off hook:



Press.
Conversation via the handset.



Mute

Press to switch the microphone on or off.
When the lamp is lit, the person on the line cannot hear what is being said near to your phone.

Hold

You can temporarily put the ongoing call on hold.



Press the ongoing call Line key and replace the handset.

The key lamp flashes slowly and the display shows the call on hold.

Note: You can also press **Hold** (see display) and replace the handset.



Press the flashing Line key again to resume the call.

Common Hold

Common hold is a feature that allows you to pick up a call, that is put on hold, from any other monitoring telephone, provided that your telephone is represented by a monitoring key on the other telephone.

Note: A call that is connected to a conference member cannot be put on common hold.

Initiate common hold:



Press the ongoing call Line key.

The key lamp flashes slowly and the display shows the call on common hold.

Note: You can also press **Hold** (see display).



Replace the handset.

Pick up a call on common hold:

When a call is put on common hold, the monitoring key on the represented extension flashes.



Press the flashing Monitoring key

or

call the extension where common hold was initiated.

Then make a call pick-up either by pressing the function key or by suffix dialing.





Line

Refer back a call on common hold:

Press the Line key where the call is on common hold.

You are now reconnected to the ongoing call.

Note: A call that is put on common hold cannot be referred back if it was answered by a monitoring extension.

Inquiry

You have a voice connection on Line 1 and want to make an Inquiry to an internal or external party.



Inquiry

Press.

The first call is put on hold (Line 1 flashes slowly).

Note: You can also press Line 2.



Call the third party.

When the other party answers, you can switch between the calls (Refer Back), Transfer the call, create a Conference or end one of the calls.



C

Press to end the Inquiry call.

The third party is disconnected.



Line 1

Press to return to the first call.

Refer Back

The Line key lamp flashes for the call put on hold. The display shows the connected call with large characters, and the call put on hold with small characters.

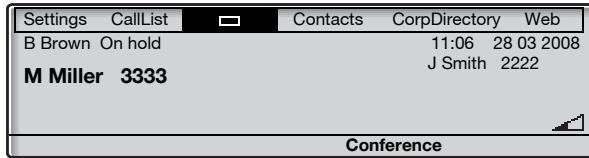

Line 1

Press to put the third party on hold.

First call is connected.



Inquiry

Press to put the first call on hold.

Third party is connected.

Note: You can also press Line 2 if you have initiated the Inquiry on Line 2.



Press to terminate the connected call.

Transfer

You have an ongoing call and you want to transfer the call to another extension.

Conf/Transf

Press (see display).

Note: You can also press Inquiry or a free Line key.



Call the third party.



Transfer

Press before or after answer.

The ongoing call is transferred.

Note: If you have put more than one call on hold, the last call that was put on hold will be transferred. If the dialed extension is busy or Transfer is not allowed, your phone will ring again.

Conference

With this procedure you can include up to seven parties in a conference. Only the conference leader (the person initiating the conference) can admit participants. The conference tone will be heard every 15 seconds during the conference. The tone is also heard each time a participant enters or leaves the conference.

Note: *The conference tone might be disabled for your system.*

You have an ongoing conversation (Line 1) and want to establish a phone conference. You will become the conference leader.

Conf/Transf

Press (see display).

Note: *You can also press Inquiry or Line 2.*



Call the third party.

Wait for answer.

Conference

Press to establish a conference (see display).

The display shows:

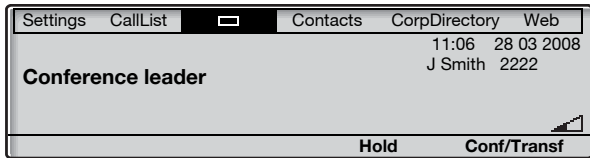

Repeat the procedure to add more conference members.



Replace the handset to leave the conference.

Note: *When the conference leader leaves the conference, the conference will continue with the other included parties. The conversation is changed back to a normal two party connection when there are only two parties left.*

Call Forwarding

Internal Follow-me

All calls to your extension are diverted to another extension of your choice (within the private network). The Follow-me lamp indicates that you have activated Follow-me. During Follow-me, your phone can still be used for outgoing calls and you will hear a special dial tone when you lift the handset.

Order from your own extension

Note: The Follow-me key is only used as an indicator that Follow-me is activated. Follow-me cannot be activated by pressing this key.

Absence

Press (see display).

The display shows:

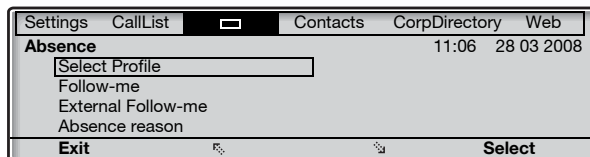

Press (see display).

Repeat until the Follow-me menu is framed.

Select

Press (see display).



OK

Enter the answering position number and press (see display).

Note: You can also use the following procedures to activate: dial *21* (U.K. *2*), dial the answering position number, press # and press the Clear key.

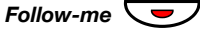

Cancel from your own extension

Press.

The Follow-me key lamp is off.

Note: You can also use the following procedure to cancel: dial **# 2 1 #** (U.K. **# 2 #**) and press the Clear key.

Redirect from answering position

If you move from one answering position to another answering position, you can redirect Follow-me from that new position.

Note: Internal Follow-me must be ordered from your own extension before you can redirect from answering position.

Absence



Press (see display).

Press (see display).

Repeat until the Follow-me menu is framed.

Select

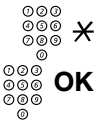

Press (see display).

Enter your own extension number and press.

Enter the new answering position number and press (see display).

Calls are diverted to the new answering position.

Note: You can also use the following procedures to redirect: dial *** 2 1 *** (U.K. *** 2 ***), dial your own extension number, press *****, dial the answering position number, press **#** and press the Clear key.

Cancel from answering position

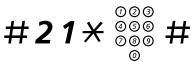

Dial, enter your own extension number and press.

Note: U.K., dial **# 2 * No #**.



Press.

External Follow-me

If external Follow-me is allowed you can have all calls to your extension diverted to an external number of your choice. The Follow-me lamp indicates that you have activated Follow-me. During Follow-me, your phone can still be used for outgoing calls and you will hear a special dial tone when you lift the handset.

Order

Note: The Follow-me key is only used as an indicator that Follow-me is activated. Follow-me cannot be activated by pressing this key.

Absence



Press (see display).

Press (see display).

Repeat until the **External Follow-me** menu is framed.

Settings	CallList	<input type="checkbox"/>	Contacts	CorpDirectory	Web
Absence			11:06	28 03 2008	
Select Profile					
Follow-me					
External Follow-me					
Absence reason					
Exit					Select

Select



OK

Press (see display).

Enter the digit or digits to get an external line and enter the external number and press (see display).

Note: You can also use the following procedure to activate: dial *22#, enter the digit or digits to get an external line, enter the external number, press # and press the Clear key.

Cancel

Follow-me 

Press.

The Follow-me key lamp is off.

Note: You can also use the following procedure to cancel: dial #22# and press the Clear key.

Personal Number

With this feature you can be reached on your normal office phone number even if you are out of the office, at home, and so on.

Depending on the functionality of your telephone system, you can have either one individual single search profile (standard) or you can choose between five individual search profiles (optional).

A search profile can be designed to fit the situation (in the office, traveling, at home, and so on). Both internal or external phone numbers can be used in a profile.

Your search profile is programmed or modified by your system administrator. See section [“To design and order your search profiles”](#) on page 73.

When the feature is activated, incoming calls are transferred to your selected phones or back-up services in the order that you choose. If an answering position in the profile is busy, the call can be transferred to another predefined position in the profile (Voice Mail or a colleague).

You can handle the profiles from your own office phone. How to do this is described here (an operator can also assist you).

You can also use any of the Personal Assistant applications, if available. Contact your system administrator for more information.

When out of the office, the feature Direct Inward System Access (DISA) can be used, if available in your system. How to use DISA is described in this section.

To activate or change to another profile from your office phone

Absence Press (see display).

The display shows:

Settings	CallList	<input type="checkbox"/>	Contacts	CorpDirectory	Web
Absence			11:06 28 03 2008		
<input type="text" value="Select Profile"/>					
Follow-me					
External Follow-me					
Absence reason					
Exit			Select		

Select Press (see display).

(1 – 5) Press the search profile digit.

OK Press (see display).

Notes:

You can also use the following procedure to activate: dial *10*, enter the search profile digit (1-5), press # and press the Clear key.

When another party is included in the activated profile, for instance a colleague or an operator, always remember to inform them about your absence. If Voice Mail is included in the activated profile, always update your greeting with Absence Information.

To cancel from your office phone

- Absence** **Press (see display).**
- Select** **Press (see display).**
- No Profile** **Press (see display).**

Note: You can also use the following procedure to cancel: dial **# 1 0 #** and press the Clear key.

To activate or change to another profile from an external phone

The external phone must be of push button type provided with pound key (#) and star key (*) or a mobile phone adapted for dial tone pulses (DTMF).



Call the DISA feature at your office.
Dial tone.

*** 7 5 ***

Dial.



Enter the Authorization Code and press.



Dial your own extension number and press.
Dial tone.

*** 1 0 ***

Dial.



Dial your own extension number and press.

(1 - 5)

Press the search profile digit.



Press and replace the handset.

Note: When another party is included in the activated profile, for instance a colleague or an operator, always remember to inform them about your absence. If Voice Mail is included in the activated profile, always update your greeting with Absence Information.

To cancel from an external phone

The external phone must be of push button type provided with pound key (#) and star key (*) or a mobile phone adapted for dial tone pulses (DTMF).

**Call the DISA feature at your office.**

Dial tone.

*** 7 5 ***

Dial.



Dial the Authorization Code and press.



#

Dial your own extension number and press.

Dial tone.

1 0 *

Dial.



#

Dial your own extension number and press.



Replace the handset.

To design and order your search profiles

The search profiles are installed or changed by your system administrator. In order to set up your profiles, copy the setting form, fill in your new or changed profiles and give it to your system administrator.

Note: *If a profile handling application is connected to your system, you can edit profiles via your Intranet. See separate instructions for the application.*

Important notes when designing your search profiles:

- Avoid ring times longer than 45 seconds for your profiles.
Usually the caller hangs up after 3-6 ring signals. If you need a longer ring time, the maximum time is 60 sec.
- Consider the time you need to react and answer on each answering position in your profile.
You might need up to 15 seconds to react and answer a call on a desk or cordless phone and 20–25 seconds for a mobile phone.
- There must be an answering position at the end of every profile (Voice Mail or operator/secretary).
If not, calls might end up unanswered.
- Consider what should happen while you are busy on a phone.
The available options are:
 - *Activate Free on 2nd (if available)*
 - *Follow-me to Voice Mail*
 - *Follow-me to the operator*
- If an answering machine, a fax or other answering device is used as an early answering position, it might interrupt the searching.
Disconnect the answering device, or design the ring times so they do not affect the searching.
- If your system admits just one single personal profile, design the profile only with your 2–3 most frequently used positions.
If you add more numbers, there is a risk that the caller hangs up before a latter position is called.
- Make sure you use as few answering positions as possible for each profile. Profile examples:
 - *In office*
 - *At home*
 - *Traveling*
 - *Absent/not reachable*

Example:

How to fill in your setting form for search profiles:

Profile 1

In office

Search order	Type of telephone or Answering position*	Telephone number	Ring time (seconds)
1	Desk	1234	10
2	Cordless	5234	15
3	Voice Mail		

* Examples: Desk, Cordless, Mobile, External, Voice Mail, Operator, and so on.

Profile 2

At home

Search order	Type of telephone or Answering position*	Telephone number	Ring time (seconds)
1	External	222222	20
2	Mobile	0706666666	25
3	Voice Mail		

Setting form for search profiles

Name:

Department:

Telephone No:

Account:

Profile 1

Search order	Type of telephone or Answering position*	Telephone number	Ring time (seconds)
1			
2			
3			
4			

* Examples: Desk, Cordless, Mobile, External, Voice Mail, Operator, and so on.

Profile 2

Search order	Type of telephone or Answering position*	Telephone number	Ring time (seconds)
1			
2			
3			
4			

Profile 3

Search order	Type of telephone or Answering position*	Telephone number	Ring time (seconds)
1			
2			
3			
4			

Profile 4

Search order	Type of telephone or Answering position*	Telephone number	Ring time (seconds)
1			
2			
3			
4			

Profile 5

Search order	Type of telephone or Answering position*	Telephone number	Ring time (seconds)
1			
2			
3			
4			

Absence Information

Absence Information is used to inform callers why you are absent and when you will return. If you are authorized, you can also enter Absence Information for another extension from your extension. During Absence Information, your phone can still be used for outgoing calls and you will hear a special dial tone when you lift the handset.

Order

Absence



Press (see display).

Press (see display).

Repeat until the **Absence Reason** menu is framed.

Select

Press (see display).

The display shows:

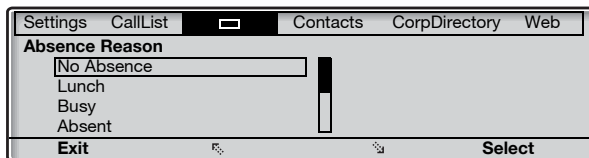

Press until the desired absence type is framed (see display).

Select



OK

Press (see display).

Enter the time or date of return (if required) and press (see display).

The display shows the selected reason and, if entered, time/date of return.

Notes:

You can also use the following procedure to order:
dial * 2 3 *, enter the absence code (0-9), enter time or date of return (if required), press # and press the Clear key.

The absence codes consist of one digit. The absence code assigned to each digit depends on the connected telephone system. Contact your system administrator regarding the available absence codes.

Cancel

Absence

Press (see display).



Press (see display).

Repeat until the **Absence Reason** menu is framed.

Select

Press (see display).

The **No Absence** menu is framed.

Select

Press (see display).

The programmed information is erased.

Note: You can also use the following procedure to cancel:
dial # 2 3 # and press the Clear key.

Order for another extension

* 2 3 0 *

Dial.



Dial the extension number and press.

(0 - 9)

Enter the absence code.

* 0 9 1 5

Press and enter the date or time of the other person's return.

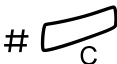

Press.

The display on the other person's extension shows the selected reason and, if entered, time or date of return.

230* 



Cancel for another extension

Dial, enter the extension number and press.

Note: *If the special dial tone is received, the Authorization Code for the other extension is required. Add the code and press # before pressing the Clear key.*

Press.

Messages

Manual Message Waiting (MMW)

If the called extension does not answer you can initiate a message waiting indication on that extension (if this feature is allowed). If there is a message waiting, the Message key lamp is on and you will hear a special dial tone after lifting the handset.



Message

Answer

Press.

A call is initiated to the extension that requested Message Waiting.

Note: *After the call you have to cancel the message indication manually, see below.*

3 1



Cancel MMW at your own extension

Dial.

Press.

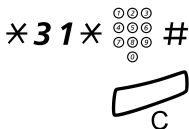

Order MMW to another extension

In idle mode:

Dial, enter the extension number and press.

Press.

The Message Waiting key lights up on the called extension.

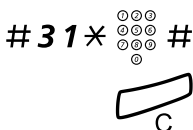

Cancel MMW to another extension

Dial, enter the extension number and press.

Press.

Message Waiting

If your phone is assigned this feature and if it is diverted to an interception computer, the Message key lamp is lit when there are messages stored for you in the computer. The messages will be printed out on a printer connected to the computer.



To print out messages

Press.

The display shows the identity of the computer and the number of messages stored for you.

If you find that the notification of Message Waiting is intrusive or you want to shut off the notification:

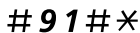

Dial.

Acknowledgement tone.

Voice Mail (optional)

This Voice Mail application allows you to leave a voice message to the caller when you are unable to answer calls, for example when out of office, in a meeting, and so on. The caller can then leave a message in your mailbox. When back in your office you can enter your mailbox and listen to the messages received.

You can choose to divert all incoming calls to your mailbox, or calls when there is no answer, or calls when your phone is busy.

If you use the Personal Number feature, it is recommended to program Voice Mail as the last answering position for all search profiles.

When you enter your mailbox, you will hear recorded instructions on how to handle listening, recording, storing and deleting messages, and how to change your security code.

Note: *How to handle your mailbox, depends on the type of Voice Mail system. The following describes the, in MD110, integrated type. For other types, please refer to separate user instructions. Contact your system administrator if you do not know which type of Voice Mail system you have.*

To activate and deactivate your mailbox

For all incoming calls:

See section “[Internal Follow-me](#)” on page 67. Use the number to the Voice Mail system as the “answering position number”.

To access your mailbox

From your office phone:



Dial the number to the Voice Mail system.

Note: When the Message key lamp is lit (= a new message is received), you can also press this key.

If you are asked to enter your security code:



Enter your security code.

Code at delivery = your extension number.

From another phone:



Dial the number to the Voice Mail system.

If you are asked to enter your security code (if the phone you are using has a mailbox of its own):

#

Press.



Dial your mailbox number.

(normally your office extension number)



Enter your security code (if required).

To access someone else's mailbox

Dial the number to the Voice Mail system.



If you are asked to enter your security code (if the phone you are using has a mailbox of its own):

#

Press.



Dial the mailbox number.

(normally the office extension number of the person served)



Enter the security code of the other person (if required).

To handle the mailbox

Recorded information on the line tells you the number of new and stored messages. If you have too many messages stored, you will first be asked to delete saved messages.

Recorded instructions ask you to press different digits in order to listen to caller's messages, record your own greetings, change your password or exit your mailbox, and so on.

The following diagram gives an overview of the mailbox system and the digits to be used.

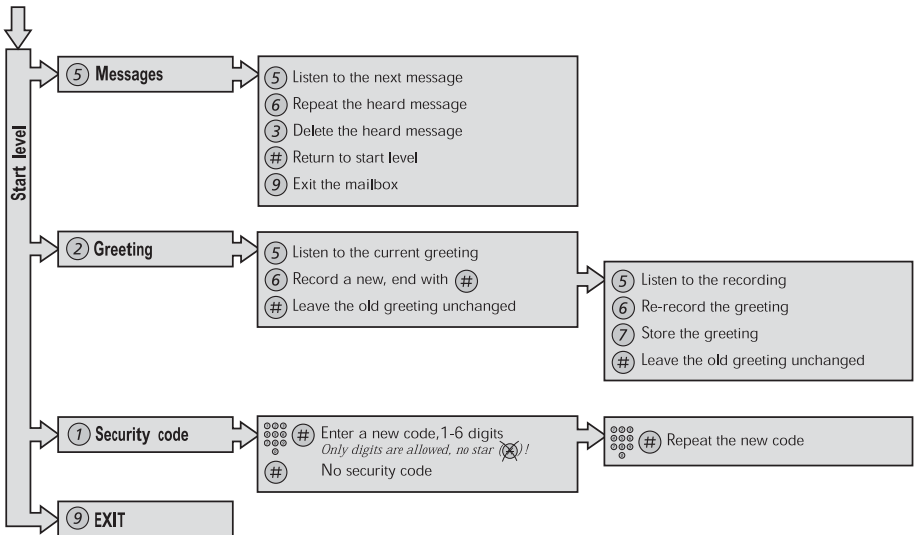

Group Features

Group Call-pick-up

People working in a team can have their phones programmed by their system administrator to form Call-pick-up groups.

In a Call-pick-up group, any member can answer any individual call to group members.

*** 8 #**

Press to answer.

Notes:

One Call-pick-up group can serve as an alternative to another group. Calls to the alternative group can only be answered when there are no calls to your own group.

*Finland and Sweden, press * 0 #.*

Common Bell Group

Calls are signalled on a common bell.

*** 8 #**

Press to answer.

Note: *Finland and Sweden, press * 0 #.*

Group Hunting

An internal Group Hunting number is a common directory number for a group of extensions. Calls to the group will be indicated at a free extension in the group.

When you leave the group temporarily, you make your phone unavailable for incoming calls.

*** 2 1 ***  **#**



To leave the group temporarily

Dial, enter your own extension number and press.

Note: *U.K., dial * 2 * No #.*

Press.

2 1



To re-enter the group

Dial.

Note: *U.K., dial # 2 #*

Press.

Other Useful Features

Account Code

This feature is used to charge a call to an account number or to prevent unauthorized calls from your phone. The Account Code can have 1 to 15 digits.

✳️ **6 1** ✳️  #

Dial, enter the Account Code and press.

Dial tone.

Note: *Finland and Norway, dial ✳️ 7 1 ✳️ Code #.*



Dial the digit or digits to get an external line and the external number.

Ongoing external call

When used to charge a call it is also possible to connect an ongoing external call to an Account Code. During the call:

 **Line**
✳️ **6 1** ✳️  #

Press the ongoing call Line key to put the call on hold.

Dial, enter the Account Code and press.

Dial tone.

Note: *Finland and Norway, dial ✳️ 7 1 ✳️ Code #.*

 **Line**

Press the flashing Line key for the call put on hold.

General Deactivation

The following features can be simultaneously cancelled:

- Callback (all Callbacks are cancelled)
- Internal and External Follow-me
- Manual Message Waiting/Absence Information

0 0 1



Order

Dial.

Press.

Emergency mode

In the event of an emergency the operator can set the telephone system into Emergency mode, during which only preprogrammed extensions are permitted to make calls. If your extension is not assigned with this category and you try to make a call, you will not receive a dial tone.

Night Service

When the telephone system is in Night Service mode, all your incoming calls to the operator are transferred to a selected extension or group of extensions. The telephone system has three different Night Service modes:

Common Night Service

All incoming calls to the operator are transferred to one specific extension. Answer the call in the normal way.

Individual Night Service

Selected external calls to the operator are transferred to one specific extension. Answer the call in the normal way.

Universal Night Service

All incoming calls to the operator are transferred to a universal signalling device, for example the common bell. Answer the call as described in section “[Common Bell Group](#)” on page 85.

Key Monitoring

It is possible to monitor and to answer calls to other extensions from a programmable function key on your phone. This feature is useful in for example Boss-Secretary applications. To answer calls on a Monitoring key, see section [“Answer calls”](#) on page 36.

The following status can be indicated on the Monitoring key:

- 1 The monitored extension is free (lamp is off).
- 2 The monitored extension has an incoming call (lamp is flashing fast).
- 3 The monitored extension is busy (lamp is on).
- 4 The monitored extension has performed common hold (lamp is flashing slowly).

The Monitoring keys are programmed by your system administrator, however you can change the type of ring signal from your phone, see section [“Change ring signal for a Monitoring key”](#) on page 106.

When you log on to another IP phone the Monitoring keys are automatically moved to the new phone.

To make calls on a Monitoring key, see section [“Speed Dialing”](#) on page 49.

Hot-Line (Non dialed connection)

An extension number can be defined as a direct hot-line. Lift the handset or press a line-key and the call is automatically generated to a predefined extension position or external subscriber.

Malicious Call Tracing

When a malicious call is received a signal can be sent to the switched telephone network (PSTN) before a call is disconnected. If the calling subscriber clears the call, the external line can be held for a limited period of time to invoke the malicious call tracing.

The system administrator assigns the MCT to a function key.

The MCT can be ordered by pressing the MCT key:

- If the request is successful, the lamp (LED) is lit, a text message is shown in the display and an acknowledge tone is heard.
- If the request fails, the lamp (LED) associated to the key flashes rapidly, a text message is shown in the display and a reject tone is heard.

DISA = Direct Inward System Access

If you are assigned to use this feature and you are working externally, you can call your office and get access to an external line in order to make business calls. The business call will be charged your office extension number or an account number. You will be charged just for the call to the office.

The external phone must be of push button type provided with Pound key (#) and Star key (*) or a mobile phone adapted for dial tone pulses (DTMF).

After a completed DISA call you must hang up before a new DISA call can be made.

There are different procedures depending on the type of Authorization Code, or when an Account Code is used.

With common Authorization Code



Call the DISA feature at your office.

Dial tone.

*** 7 2 ***

Dial.



#

Dial the Authorization Code and press.

Dial tone.



Dial the external number.

With individual Authorization Code



Call the DISA feature at your office.

Dial tone.

*** 7 5 ***

Dial.



Dial the Authorization Code and press.



#

Dial your own extension number and press.

Dial tone.



Dial the external number.

Settings

Checking the protocol

There are two User Guides for the Dialog 4425 telephone; one intended for the SIP protocol based telephone, and one for H.323 protocol based telephone. In order to know which User Guide to use, you need to check which protocol is used in your telephone.

To check the used protocol:



Press the Left navigation key (<) until Settings is high-lighted in the tab field.

Select the **Information** menu.

The current protocol and software version are displayed, see below.

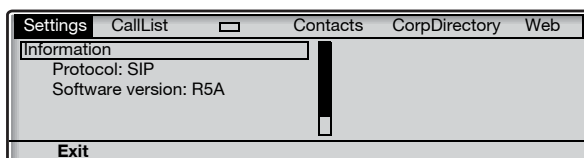

Programming of function keys

Frequently used features (*XX#) and phone numbers can be programmed on the function keys for easy access. When you want to use the feature or phone number, just press the key. Certain features must be preprogrammed by your system administrator.

Note: *To be able to program a function key, the phone normally has to be logged on to the telephone system (this is set by your system administrator).*

Program or change a feature



Select Settings in the top menu (see display).

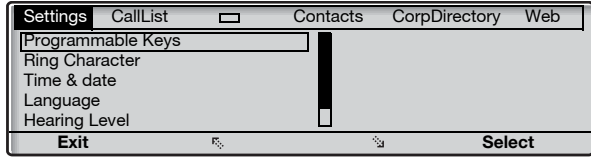

Select

Press to select the Programmable Keys menu (see display).



Press the key to program.

***Note:** If the key is already programmed, the number or feature will be displayed.*



Enter phone number or a procedure.

Notes:

A procedure can be, for example the ordering of Follow-me, (2 1 * Number #).*

*If you want to delete a character, press **Erase**, and then enter the character again.*

You can continue programming another function key (repeat from “Press the key to program”).

*The menu key **Cancel** can be used to leave the menu without saving the changes.*

Save

Press to save (see display).

Exit

Press to return to the previous menu (see display),

or



press to return to idle mode.

Remove the transparent cover and write the feature name or phone number beside the key.

Note: Use the DCM (Designation Card Manager) to make and print your own designation cards. DCM is included on the Enterprise Telephone Toolbox CD or it can be downloaded from:
<http://www.aastra.com>

For more information, please contact your Aastra Certified Sales Partner.

Verify a programmed number or feature



Select



Select Settings in the top menu (see display).

Press to select the Programmable Keys menu (see display).

Press the function key.

The stored number or procedure code is shown on the display.

Settings	CallList	<input type="checkbox"/>	Contacts	CorpDirectory	Web
Programmable Keys					
Current number: 0046181100					
Enter new number:					
Cancel			Save		

Cancel

Press (see display).

Exit

Press to return to the previous menu (see display),

or



press to return to idle mode.

Language

You can change the display menu language and keypad character map. Available languages are listed when the language menu is selected. The phone must be logged on to change the language.

Note: *If the chosen language is not supported by your telephone system, text sent from the system will continue to be in English. Only text displayed from the phone itself will be in the chosen language.*

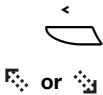

Select

Select

Change display menu language (default=English)

Select Settings in the top menu (see display).

Press (see display).

Repeat until the **Language** menu is framed.

Press (see display).

Display menus is framed.

Press (see display).

The current language is framed and marked (English is default).

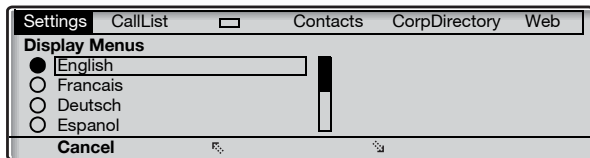

Select

Exit

Press until the desired language is framed (see display).

Note: *The menu key **Cancel** can be used to leave the menu without saving the changes.*

Press to store the framed language (see display).

The display language is changed. The acknowledgement tone is heard.

Press to return to the previous menu (see display),

Note: *The word **Exit** is displayed in the selected language.*

or



press to return to idle mode.

Change keypad character map

You can change the character map for the keypad to get correct local characters when for example writing names in **Contacts** (PhoneBook).

Note: You can find the default character map in section *"Character map"* on page 57.



Select Settings in the top menu (see display).



Press (see display).

Repeat until the **Language** menu is framed.

Select

Press (see display).



Press (see display).

Until the **Keypad characters** menu is framed.

Select

Press (see display).

The current character map is framed and marked.



Press until the desired character map is framed (see display).

Note: The menu key **Cancel** can be used to leave the menu without saving the changes.

Select

Press to store the framed character map (see display).

Exit

Press to return to the previous menu (see display),

or



press to return to idle mode.

Date presentation

The date is updated automatically from the telephone system. You can only change the way the date (format) is presented on the display. The date can be shown in eight different ways:

<i>Format</i>	<i>Example</i>
• DD-MM-YYYY	22-02-2008
• DD-MM-YYYY	Fr 22-02-2008
• DD-MM-YYYY	22 02 2008
• DD-MM-YYYY	22 Feb 2008
• DD-MM-YYYY	Fr 22 Feb 2008
• YYMMDD	080222
• YYYY-MM-DD	2008-02-22
• MM/DD/YYYY	02/22/2008

To change the date presentation:



Select Settings in the top menu (see display).



Press (see display).

Repeat until the **Time & date** menu is framed.

Select

Press (see display).



Press (see display).

Repeat until the **Date Format** menu is framed.

Select

Press (see display).

The current date presentation is framed and marked:

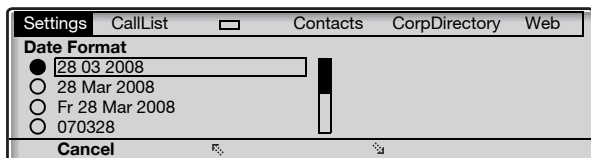

Press until the desired date format is framed (see display).

Note: The menu key **Cancel** can be used to leave the menu without saving the changes.

Select

Press to store the framed date format (see display).

Exit

Press to return to the previous menu (see display),

or



press to return to idle mode.

Time presentation

The time is updated automatically from the telephone system. You can only change the way the time (format) is presented on the display. The time can be shown in 24 or 12 hour clock mode.

To change the time presentation:

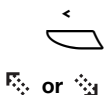

Select Settings in the top menu (see display).

Press (see display).

Repeat until the **Time & date** menu is framed.

Select

Press (see display).

The **Time Format** menu is framed.

Select

Press (see display).

The current time presentation is framed and marked:



Press to toggle between the values 12 hour and 24 hour mode (see display).

***Note:** The menu key **Cancel** can be used to leave the menu without saving the changes.*

Select

Press to store the framed time format (see display).

Exit

Press to return to the previous menu (see display),

or



press to return to idle mode.

Programming of ring signal tone character

There are 10 different programmable ring signal tone characters on your phone, each corresponding to a digit between 0 and 9.

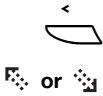

Select Settings in the top menu (see display).

Press (see display).

Repeat until the Ring Character menu is framed.

Select

Press (see display).

The current tone character is displayed.

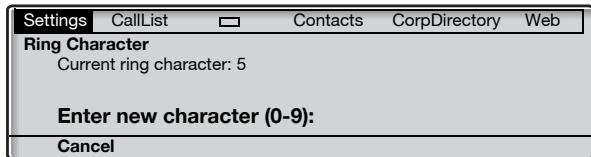

(0-9)

Press a digit to select a new character.

The phone rings with the chosen character.

*Note: The menu key **Cancel** can be used to leave the menu without saving the changes.*

Save

Press to store the selected character (see display).

Exit

Press to return to the previous menu (see display),

or



press to return to idle mode.

Display contrast

The display contrast can be changed.

Change the contrast on the display

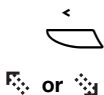

Select Settings in the top menu (see display).

Press (see display).

Repeat until the **Display Contrast** menu is framed.

Select

Press (see display).

The display shows:

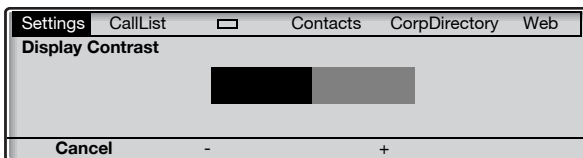

- or +

Press to decrease or increase the contrast (see display).

Note: The menu key **Cancel** can be used to leave the menu without saving the changes.

Save

Press to store the contrast level (see display).

Exit

Press to return to the previous menu (see display),

or



press to return to idle mode.

Backlight

(Dialog 4425 v. 2 phone only).

The display backlight level can be changed.

Change the backlight level on the display

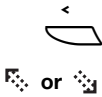

Select Settings in the top menu (see display).

Press (see display).

Repeat until the Display Backlight menu is framed.

Select

Press (see display).

The display shows:

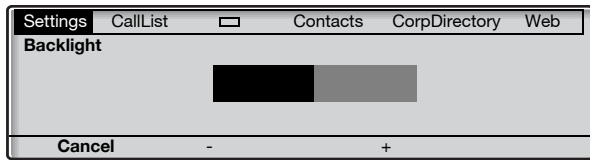

- or +

Press to decrease or increase the backlight level (see display).

*Note: The menu key **Cancel** can be used to leave the menu without saving the changes.*

Save

Press to store the backlight level (see display).

Exit

Press to return to the previous menu (see display),

or



press to return to idle mode.

Option unit

If your phone is equipped with an option unit, you can use this menu to select the function of the option unit.

Change the function of the option unit

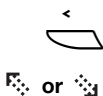

Select Settings in the top menu (see display).

Press (see display).

Repeat until the **Option unit** menu is framed.

Select

Press (see display).

The display shows:



Press to change between the features (see display).

- **Extra Bell:** The extra bell is activated in parallel with the ring signal. A free on second call does not activate the extra bell feature.
- **Busy Signal:** The busy signal is activated when your phone is busy (during calls). The feature can be used to control for example a Do-not-disturb lamp at the door.
- **Combined Bell/Busy:** Activated in parallel with the ring signals and steady active when your phone is busy (during calls). A free on second call does not activate the extra bell feature.

Note: The menu key **Cancel** can be used to leave the menu without saving the changes.

Select

Press to store the selected feature (see display).

Exit

Press to return to the previous menu (see display),

or



press to return to idle mode.

Handset and loudspeaker volume

Use the Volume keys to adjust the volume of the handset or loudspeaker during a call. Adjust the handset listening volume when the handset is off hook. Adjust the loudspeaker volume when dial tone is heard via the loudspeaker, or during a handsfree call.



Press to adjust the volume.

The handset and loudspeaker volume level is stored.

Hearing level settings

It is possible to get an increased hearing level of +6 dB in the handset and headset.

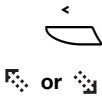

Select Settings in the top menu (see display).

Press (see display).

Repeat until the **Hearing Level** menu is framed.

Select

Press (see display).

The current hearing level is framed and marked.

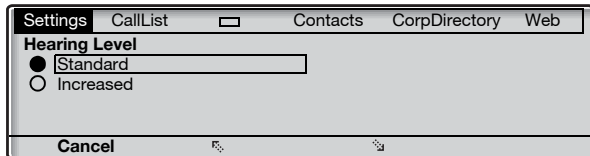

Press to toggle between the values Standard and Increased (see display).

Note: The menu key **Cancel** can be used to leave the menu without saving the changes.

Select

Press to store the framed hearing level (see display).

Exit

Press to return to the previous menu (see display),

or



press to return to idle mode.



Ring signal volume

Use the Volume keys to adjust the ring signal volume when the phone is in idle mode or ringing. Adjusted volume is stored.

Press to adjust the volume.

Note: *The volume will return to the default level in case of a power failure.*

Mute ring signal

You can suppress the ring signal for an incoming call.



Press to suppress the ring signal.

The ring signal is switched off for the current call, and your phone is automatically set to Silent Ringing.

Silent Ringing

If you do not want to be disturbed by the ring signal but still want to be able to answer an incoming call, you can switch off the ring signal. Incoming calls are only indicated by a flashing line lamp and display information.



When the phone is in idle mode, or when ringing:

Press to switch off the ring signal.

The Mute key lamp is switched on and the Volume level bar is replaced by the Ringer off symbol to indicate Silent Ringing. The ring signal will automatically be switched on the next time you lift the handset or press any key.

Change ring signal for a Monitoring key

The Monitoring keys are programmed by your system administrator, however you can change the type of ring signal from your phone. See also section "Key Monitoring" on page 90.

Change the type of ring signal



Select

Select Settings in the top menu (see display).

Press to select the Programmable Keys menu (see display).

Press the Monitoring key to program.

The extension number of the phone that is monitored is shown together with the current type of ring signal for the key.

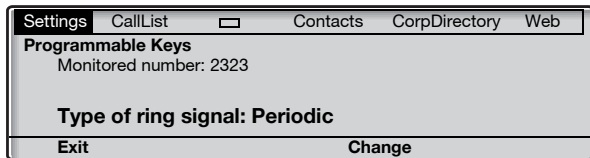

Change

Press (see display).



or

Press to change between the ring signals (see display).

- Silence.
- Periodic (repetitive) ring signal.
- Delayed periodic ring signal.
- One muted ring signal. Only one ring signal is generated with a low level.
- One muted delayed ring signal.

Note: The menu key **Cancel** can be used to leave the menu without saving the changes.

Select

Press to store the framed ring signal (see display).

Exit

Press to return to the previous menu (see display),

or



press to return to idle mode.

Network settings

In the **Network** menu you can check all the network settings, but you can only change the password menu presentation setting. All other settings can only be changed by your system administrator.

Password or PIN menu presentation

If you are not using a password to log on, you can set your phone to bypass the password menu during the log on procedure.

Note: *If the system requests a password for an extension number, the password menu will still be shown, even if the password presentation menu is set to **No**.*

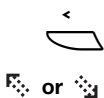

Select Settings in the top menu (see display).

Press (see display).

Repeat until the **Network** menu is framed.

Select

Press (see display).

The display shows:

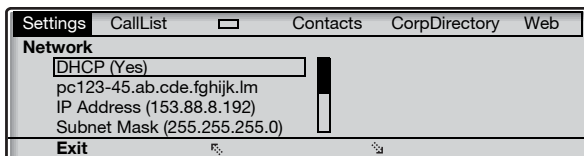

Press (see display).

Repeat until the **Password** or PIN menu is framed. The current settings are shown within brackets.

Select

Press (see display).

Change

Press to change (see display).

Note: *The menu key **Cancel** can be used to leave the menu without saving the changes.*

Save

Press to store the selection (see display).

Exit

Press to return to the previous menu (see display),

or



press to return to idle mode.

Accessories

Key panel

Your phone can be equipped with 1-4 additional key panels (type DBY 419 01). Each key panel offers 17 additional keys for storing of your most frequently used telephone numbers and features, and for monitoring extensions. To install the key panel, see section “[Installation](#)” on page 132.

Use the DCM (Designation Card Manager) to make and print your own key panel designation cards. DCM is included on the Enterprise Telephone Toolbox CD or it can be downloaded from: <http://www.aastra.com>

For more information, please contact your Aastra Certified Sales Partner.

Headset (optional)

To install the headset, see section “[Installation](#)” on page 132.

The following headset features are available.

Answer calls



Press to answer.

The Headset key lamp is turned on.

Note: When the phone is set for Headset Preset, you can also press the flashing Line key to answer the call. See section “[Headset Preset](#)” on page 110.



Press to terminate the headset call.

Make calls

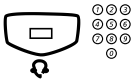

Press and dial the number.

The Headset key lamp is turned on.

Note: When the phone is set for Headset Preset, you can dial the number directly without pressing the Headset key, or you can press a Line key instead of the Headset key. See section “[Headset Preset](#)” on page 110.



Press to terminate the call.

From headset to handset



Lift the handset.

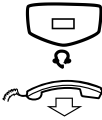

From handset to headset

Press.
The Headset key lamp is turned on.

Replace the handset.



From headset to handsfree

Press.
The Loudspeaker key lamp is turned on.



From handsfree to headset

Press.
The Headset key lamp is turned on.

Headset Preset

By default the phone is set to **Loudspeaker Preset mode**, so that calls are connected to the loudspeaker when you answer or make calls by pressing a Line key. Also when you dial the number without lifting the handset, the call is automatically connected to the loudspeaker.

When you use a headset for your telephone, you can change the setting to **Headset Preset mode** to get calls connected to the headset instead. In Headset Preset mode you can make headset calls by pressing digits directly (direct dialing). You can also answer headset calls by pressing a Line key.

Notes:

Independent the type of preset setting, when you lift the handset the call is always connected to the handset.

Also handsfree works as usual, that is when the Loudspeaker key is pressed, the call is temporarily connected to the loudspeaker.

Activation and deactivation of Headset Preset can only be done when the phone is in idle mode.

To activate Headset Preset:



Press and hold for at least 4 seconds.

A short acknowledgement tone signal is heard, and the Headset symbol is displayed.

To cancel Headset Preset:



Press and hold for at least 4 seconds.

A short acknowledgement tone signal is heard, and the Headset symbol is switched off.

To check the current preset setting:



Press.

Either the Loudspeaker or Headset key lamp is turned on, indicating the current preset setting.

Press.

Headset volume

During a call, use the Volume keys to change the volume of the headset.



Press to change the volume.

The set headset volume level is stored.

For those with impaired hearing, the headset hearing volume level can be further amplified, use the same procedure as described in section "[Handset and loudspeaker volume](#)" on page 104.

Pull-out leaf (optional)

The pull-out leaf is used for a personal phone number list and is installed under the phone. To install the pull-out leaf, see section "Installation" on page 132.

Use the DCM (Designation Card Manager) to make and print your own card for the pull-out leaf. DCM is included on the Enterprise Telephone Toolbox CD or it can be downloaded from: <http://www.aastra.com>

For more information, please contact your Aastra Certified Sales Partner.

Add Microsoft Outlook Contacts

(Dialog 4425 v. 2 phone only).

My Dialog 4000 Contacts

My Dialog 4000 Contacts is a PC application which you can use when you want to download your Microsoft® Outlook® contacts to **Contacts** in your phone.

Note: *It is recommended to store all your phone numbers in Microsoft Outlook with area and country code including the international “+” sign.*

Install My Dialog 4000 Contacts

The PC application must be installed on your PC (network access required), your system administrator should provide a link to the installation page.

On the installation page:

Make sure you have the necessary information to complete the installation (see installation page).

When you have the necessary information:

Click on [Install My Dialog 4000 Contacts now](#) to start the installation.

When the installation is complete the *My Dialog 4000 Contacts* icon is added to your desktop.

Add Microsoft Outlook contacts

Start “My Dialog 4000 Contacts” on your PC.



Enter your phone number, password and IP address.

The default password is *Welcome*. To find your IP address, see section “[Menu structure Dialog 4425 v. 2 phone](#)” on page 25.

OK

Click.

Available Microsoft Outlook contacts are listed on the left side and all contacts already in **Contacts** in your phone are listed on the right side.

Add>>

Mark the required contacts on the left hand side and click.

Selected Microsoft Outlook contacts are moved to **Contacts** in your phone.

Save

Click to save the contacts.

The contacts are now available in **Contacts** in your phone.

Note: **Contacts** in your phone can contain up to 1000 entries.

Exit My Dialog 4000 Contacts

Exit

Click to exit the PC application.

Web Server

You can access your IP phone from a PC web browser to edit the telephone data. The available data depends on which telephone version (Dialog 4425 v. 1 phone or Dialog 4425 v. 2 phone) you are using.

- **Contacts:** (Dialog 4425 v. 2 phone only) Add, change or delete entries in **Contacts**.
- **PhoneBook:** (Dialog 4425 v. 1 phone only) Add, change or delete entries in **PhoneBook**.
- **Call List:** View the list, make a call to a number in the list and delete items. It is also possible to add numbers to **Contacts (PhoneBook)**.
- **Settings:** Add, change and delete Dial by function key numbers for the programmable keys.
- **Settings:** Change the hearing level setting (standard or increased).
- **Settings:** (Dialog 4425 v. 2 phone only) Change the ring signal tone character (a digit between 0-9).

Before you use the PC, you need to find the IP address to your telephone.

Example: How to find the IP address:

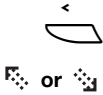

Select Settings in the top menu (see display).

Press (see display).

Repeat until the **Network** menu is framed.

Select

Press (see display).

The display shows (all addresses are examples):

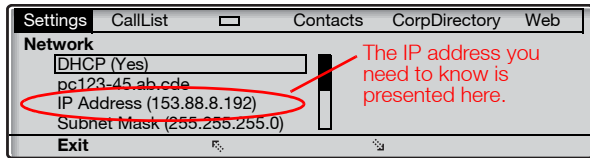

To access your IP phone from a PC

http://153.88.8.192

Enter the IP address in the address field in your web browser.
(This address is an example. The web browser shows:

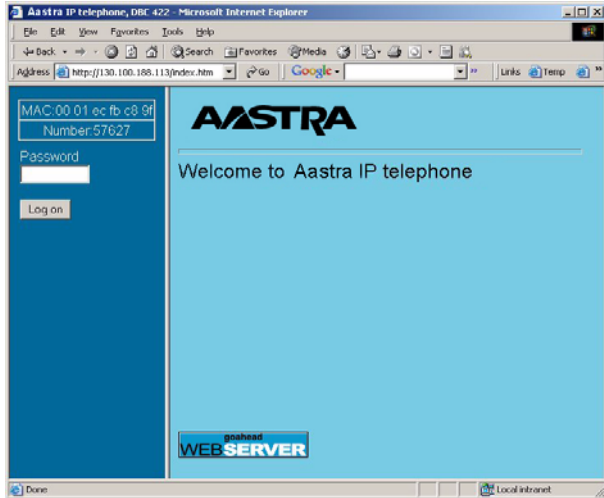

Note: If you have entered the same IP address you previously used and you could not access the web server, then check the address on your phone display. If your phone has been plugged off for a few days, the address may have been changed.

XXXXXXXX

Enter the telephone PIN or password.

Note:

The password is case sensitive.

The PIN is the same as the Individual Authorization Code. Only digits can be used as PIN. The PIN must be four digits or more.

Log on

Click.

A menu is displayed in the left column, with the following options:

  **PhoneBook**

Click  to show the PhoneBook (Dialog 4425 v. 1 phone only).

  **Contacts**

Click  to show the Contacts (Dialog 4425 v. 2 phone only).

  **CallList**

Click  to show the Call List.

  **Settings**

Click to show the sub-menus.

 **Log off**

Click to log off from the web server.

Contacts

(Dialog 4425 v. 2 phone only).

To add a new name and number to **Contacts**:

  **Contacts**

Click  .

 **Add to contacts**

Click.

Enter the name and number.

Add to contacts

Click.

The new name and number is added to **Contacts**.

To edit or delete a name and number:

 **Contacts**

Click to show the Contacts.

(Name)

Click on the name you want to edit or delete.

Save

Make the changes and click to save,

or

Delete

click to delete the current name and number,

or

Back

click to exit the edit and delete menu without any changes.

  **Contacts**

 **Delete contacts**

OK

To delete all names and numbers from **Contacts**:

Click  .

Click.

Click to delete all names and numbers.

PhoneBook

(Dialog 4425 v. 1 phone only).

To add a new name and number to **PhoneBook**:

  **PhoneBook**

 **Add to phone book**

Click  (**Dialog 4425 v. 1 phone only**),

Click.

Enter the name and number.

Add to phone book

Click.

The new name and number is added to **PhoneBook**.

To edit or delete a name and number:

 **PhoneBook**

(Name)

Save

Click to show the PhoneBook.

Click on the name you want to edit or delete.

Make the changes and click to save,

or

Delete

click to delete the current name and number,

or

Back

click to exit the edit and delete menu without any changes.

To delete all names and numbers from **PhoneBook**:

  **PhoneBook**

 **Delete phone book**

OK

Click  .

Click.

Click to delete all names and numbers.

Call List

 CallList
(Name)

Click to show the Call List.

Click.

Select one of the options below:

Add to contacts

Click to save the name and the number to Contacts (Dialog 4425 v. 2 phone only),

or

Add to phone book

Click to save the name and the number to PhoneBook (Dialog 4425 v. 1 phone only),

or

Delete

click to delete the name and number from the Call List,

or

Call

click to call the number,

or

Back

click to return to the Call List menu without any changes.

To delete all names and numbers from the Call List:

  CallList

Click  .

 **Delete call list**

Click.

OK

Click to delete the list.

Settings

● **Programmable Keys**

Settings - Programmable keys

Click.

The sub-menus are shown.

Click.

A table with the current programming for each key is shown. The key order corresponds to the programmable keys on the telephone, that is the Line 1 key is located in the left lower corner.

Note: *Text that is not underlined, is a designation for a fixed key and cannot be changed.*

To program a key that has not been programmed:

—

12345

Save

Click for the key to be programmed.

Enter the number or code (example).

Click to save.

The key table is shown with the new number or code.

To edit a programmed key:

(Number/Code)

12345

467

Save

Click the underlined number or code for the key to be changed.

Mark the characters to be changed (example).

Enter new characters (example).

Click to save.

The key table is shown with the edited number or code.

To delete a programmed key:

(Number/Code)

Delete

Click the underlined number or code for the key to be deleted.

Click to delete.

The key table is shown with “_” for that key.

● **Programmable Keys**

To exit the edit and delete menu without any changes:

Click.

Note: *You can also click the Back key.*

Settings - Hearing level

+ Settings

Click.

The sub-menus are shown.

● **Hearing Level**

Change

Click.

The current level is shown in bold characters.

Click to change the level.

The hearing level is changing between “Standard” and “Increased”.

Back

Click to return.

Settings - Ring signal tone character

(Dialog 4425 v. 2 phone only).

+ Settings

Click.

The sub-menus are shown.

● **Ring Character**

(0 – 9)

Click.

The current tone character is displayed.

Enter a new character.

Change

Click to save the new character.

The phone rings with the chosen character.

Click any menu to continue.

Corporate Directory

(Dialog 4425 v. 2 phone only).

In the Corporate Directory you can find a person's phone number and then make a call to that person. When you have accessed the directory, you have the following available options:

Underlined

Underlined text is a clickable link when marked (see display).

Options

Menu for return options (see display).

Do Search = Search the directory, **Refresh** = Refresh the content.



Move marker one step down (see display).



Move marker one step up (see display).

Home

Return to the first page of the logged on menu (see display).

If pressed for at least two seconds, you return to idle mode.



Return to the previous menu.

Return to idle mode.

Not used.

Access the Corporate Directory and make a call

Note: This feature must be activated by your system administrator.



Select CorpDirectory in the top menu (see display).

The display shows:

Settings	CallList	☐	Contacts	CorpDirectory	Web
Last Name	An_		Abc		
First name	<input type="text"/>				
Do Search			Erase		



Enter the first letters of the last name.

You can also search for first name, phone number and department.

Do Search

Press (see display).

The display shows a list of last names that begin with the entered letters, for example **An**.

Found: 4	
Home	
1. Andersen, Stina	
2. Andersson, Ann	
Select	

The **Home** link is used if you want to make a new search.



Press (see display).

Repeat until desired person is marked.

Select

Press (see display).

The display shows the directory data for the selected person.

Stina Andersen	
Last name:	Andersen
First name:	Stina
Phone:	2018
Department:	DNDI
Mobile:	000703954818
Select	



Press (see display).

Repeat until the phone number (**Phone:**) is marked.

Select

Press to make the call (see display).

Web

(Dialog 4425 v. 2 phone only).

In the Web menu you can access WAP pages (modified Internet pages) via your phone. When you have accessed the WAP pages, you have the following available options:



Return to the previous page.

Return to idle mode.

Go to the next page.

Underlined



Underlined text is a clickable link (see display).

Press a keypad key (0-9) for more than one second, to enter the corresponding digit instead of the letter.

Access the Web menu



Select Web in the top menu (see display).

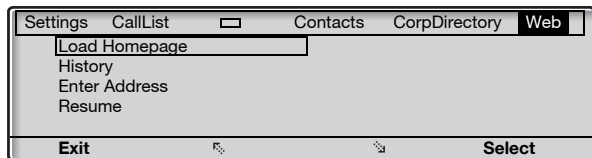

Select one of the following options:

- **Load Homepage:** Go to the home page (WAP portal). Requires that the WAP portal has been defined.
- **History:** History over visited WAP pages.
- **Enter Address:** Enter an address to another WAP page.
- **Resume:** Show the latest shown WAP page. This can for instance be used if an incoming call has changed the display and you want to go back to the WAP page again.

Enter other WAP pages



Press (see display).

Repeat until the **Enter Address** menu is framed.

Select

Press (see display).

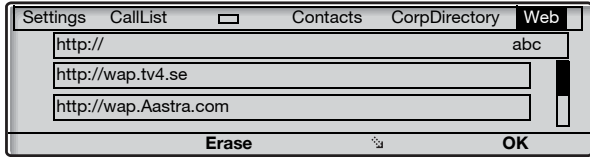

OK

Enter the WAP page address and press (see display),

The WAP page is shown. Use the display menu keys to navigate on the page.

or



OK

select a previously used WAP page and press (see display).

The WAP page is shown. Use the display menu keys to navigate on the page.

WAP Services

(Dialog 4425 v. 1 phone only).

Central Directory

In the Central Directory you can find a person's phone number and then make a call to that person. When you have accessed the directory, you have the following available options:

Underlined

Underlined text is a clickable link when marked (see display).

Options

Menu for return options (see display).

Home = Logon menu and **Exit** = Return to top menu WAP Services.



Move marker one step down (see display).



Move marker one step up (see display).

Ret

Return to the previous menu (see display).

Home

Return to the first page of the logged on menu (see display).

If pressed for at least two seconds, you return to idle mode.



Return to the previous menu.



**Short press: Return to the Logon menu.
Long press: Return to idle mode.**



Not used.

Access the Central Directory and make a call

Note: This feature must be activated by your system administrator.



Select WAP Services in the top menu (see display).

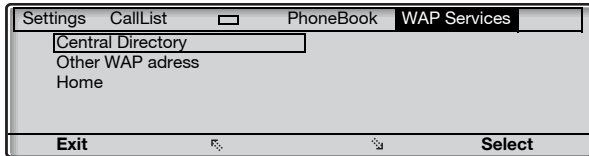

Note: The Home option is only available, when a pre-defined WAP portal is accessible.

Select

Press to select the Central Directory menu (see display).

The display shows:

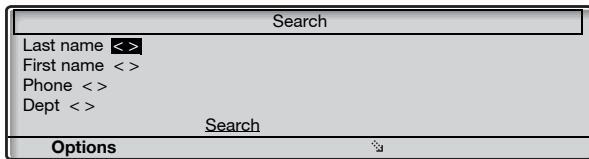

Press (see display).

Repeat until requested search criteria is marked, for example Last name.

Select



Press (see display).

Enter the first letters of the last name.



Press to reach the link Search (see display).

Select

Press (see display).

The display shows a list of names that begin with the entered letters, for example AN.

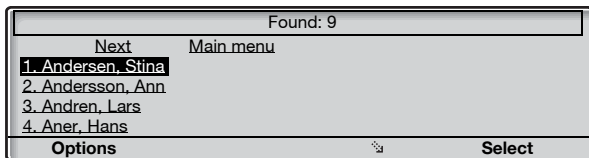

If you want to see the next page of search result hits, you can use the **Next** link. The **Main menu** link is used if you want to make a new search.

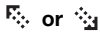

Press (see display).

Repeat until desired person is marked.

Select

Press (see display).

The display shows the directory data for the selected person.

Stina Andersen	
Last name:	Andersen
First name:	Stina
Phone:	2018
Department:	DNDI
Mobile:	000703954818
Options	Select

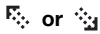

Press (see display).

Repeat until the phone number (Phone:) is marked.

Select

Press to make the call (see display).

Other WAP address



Select WAP Services in the top menu (see display).

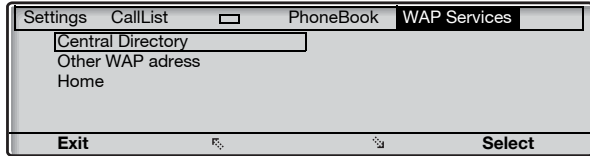

Press (see display).

Repeat until the **Other WAP Address** menu is framed.

Select

Press (see display).

The **Enter address** page is shown.



Enter the WAP address (excluding http://).

See example below.

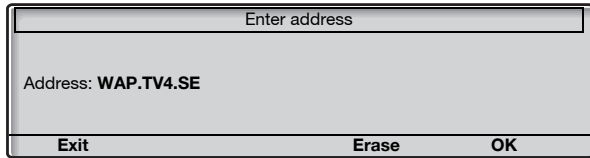

Notes:

If a keypad key (0-9) is pressed for more than one second, the corresponding digit is entered instead of the letter.

*Press * to switch between upper and lower case.*

OK

Press (see display).

The top page for the entered address is shown. Use the display menu keys to navigate on that page.

To leave the WAP page

Options

Press (see display).

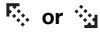

Press (see display).

Repeat until the **Exit** menu is framed.

Select

Press (see display).

You return to **WAP Services** in the top menu.

Note: You can always press  and keep it pressed for at least one second to return to idle mode.

Home

The **Home** option is used to access a pre-defined WAP portal (if a pre-defined WAP portal does not exist, this option is not available).

Installation

Install cables

Handset cable to the left

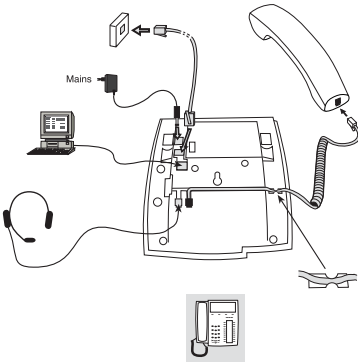

Handset cable to the right

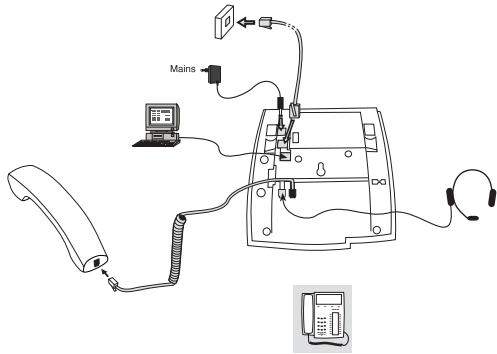

The handset cable has to be plugged into “HANDSET”, and the cable to the network has to be plugged into “LAN”. If an external power adapter is used this has to be plugged into “POWER”. You can put the cable to the handset into the notch underneath the telephone. When only one single wall terminal for the local network is available, a PC can be connected to “PC” so that it is connected to the network via the phone.

The phone can be powered either from the LAN or from a 24 V AC/AC plug-in power adapter.

- **Only use applicable 24 V AC/AC plug-in adapters (power supplies) listed below or an adapter approved by your local reseller.**

<i>Aastra product number</i>	<i>Power rating</i>	<i>Supplier</i>	<i>Supplier product number</i>
RES 141 312/1	20VA 230V/24V	Toroid, Sweden	HBP 90120
RES 141 314/1	20VA 230V/24V	Toroid, Sweden	HBP 90220 (for Great Britain, Hong Kong, Singapore)
RES 141 315/1	20VA 120V/24V	Jameco, USA	AC2410F1 (model number ADU240100)

Change cables

To remove a cable, use a screwdriver to unlock the stop.

Install stands and adapt telephone

Position high

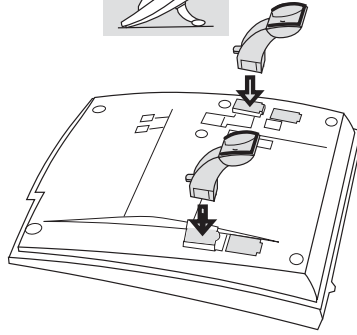

Position low

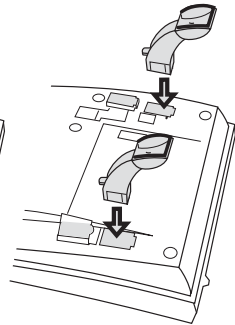

Press to fasten stand

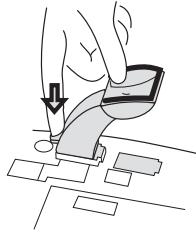

Release to remove stand

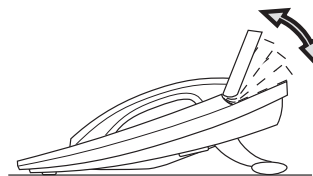
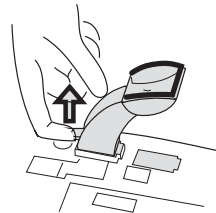

Tiltable display

Adjustable angle

Install card

Use the Designation Card Manager to make and print your own designation cards. DCM is included on the Enterprise Telephone Toolbox CD or it can be downloaded from:

<http://www.aastra.com>

For more information, please contact your Aastra Certified Sales Partner.



Install key panels

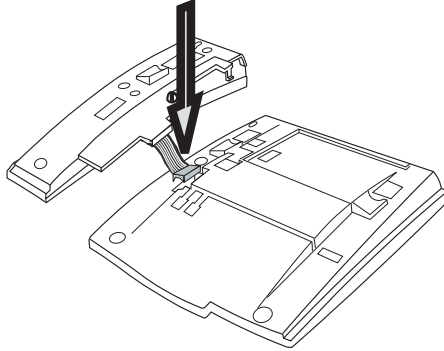

- 1 Fasten the connector in the bottom of the hole using a finger or a blunt tool. Make sure the connector fits before pressing it down.**

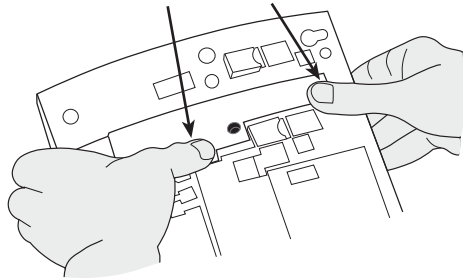
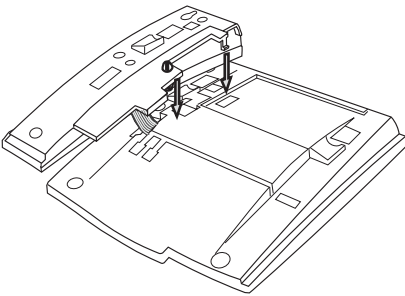

- 2 Press where the arrows are pointing, until you hear a “Click” sound.**
- 3 Install the stands as shown in the picture in section “Stand positioning”.**

Notes:

All key panels must be of type DBY 419 01.

Stand positioning (1-4 key panels)

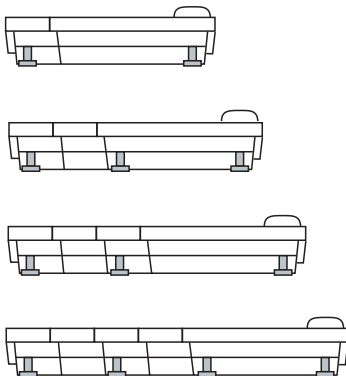

Install card

Use the DCM (Designation Card Manager) to make and print your own key panel designation cards. DCM is included on the Enterprise Telephone Toolbox CD or it can be downloaded from: <http://www.aastra.com>

For more information, please contact your Aastra Certified Sales Partner.

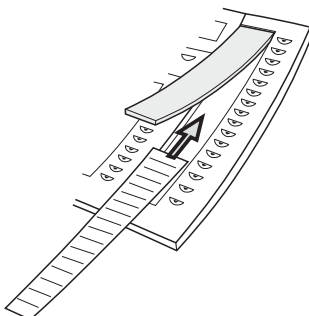

Install pull-out leaf (optional)

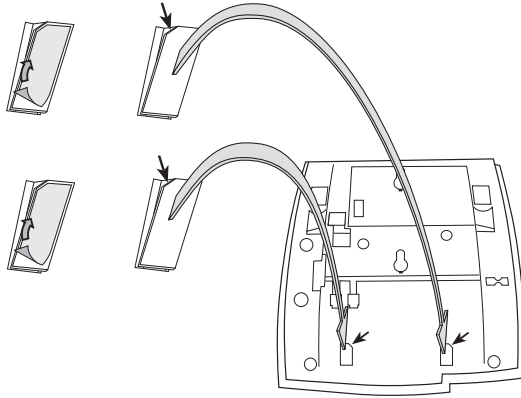

- 1 Remove the protective film from the guiding rails.**
- 2 Attach the guiding rails to the bottom of the phone, observing the direction of the “cut” corner.**

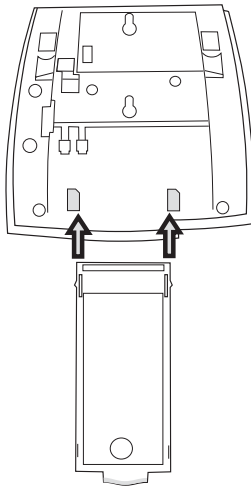

- 3 Insert the pull-out leaf.**

Wall mounting

The phone can be wall mounted, useful for instance in conference rooms or public areas.

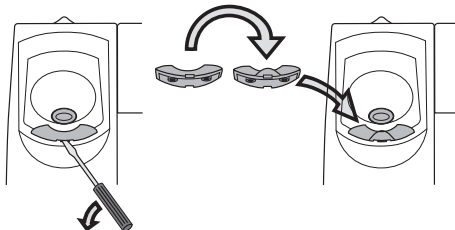

- 1 Use a screwdriver to remove the handset hook.**
- 2 Turn the hook upside down and insert.**

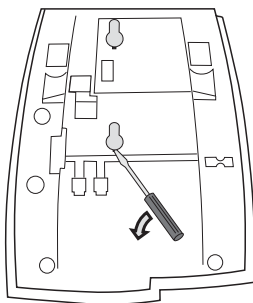

- 3 Use a screwdriver to remove the two plastic covers.**

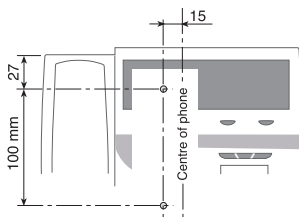

- 4 Drill appropriate wall holes according to measurements given here.**

Wall screws \varnothing max 5mm.

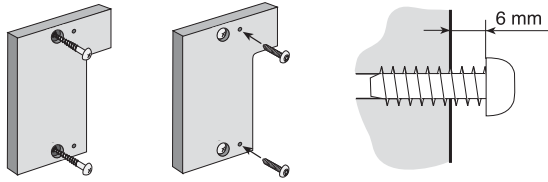

5 Mount the spacer (article no. SXX 106 2049/1) on the wall.
Wall screws (not supplied) \varnothing max 5mm.

6 Place screws according to measurements and mount the phone.

Placing the phone

Do not expose your phone to direct sunlight for long periods. Keep the phone away from excessive heat and moisture.

Cleaning

Clean your phone only with a soft, water dampened cloth. Using soap or any other cleaning materials may discolor or damage the phone.

Troubleshooting

This section contains information on how to solve common operational problems, and warnings you may receive.

Go through the following list if you encounter any problems. If this checklist does not cover the problem, contact your system administrator. If others have similar problems, there may be a system error.

Fault / Display	Probable cause	Action or comment
The phone is locked	Disturbance on the network.	Press the Clear key, Mute key and # simultaneously for one or two seconds. This will restart the phone.
The access warning triangle occurs on the display.	Disturbance on the network or in the telephone system.	Some features might not work, but the phone can be used for receiving and making calls.
No connection to network! occurs on the display	There is no connection to the network.	Verify that the phone is connected to the network by checking the connection.

Glossary

<i>Call mode</i>	The different states your phone is in; calling, ringing, forwarded, and so on.
<i>Telephone system</i>	Exchange. Switch.
<i>Idle display</i>	A message shown on the display when the phone is idle. This message is programmed by your system administrator.
<i>Idle mode</i>	The state your phone is in when nothing is activated; not calling, not ringing, not forwarded and so on.
<i>LAN</i>	Local Area Network.
<i>Speed Dialing number</i>	Abbreviated number or short number, used for making frequently used numbers faster to dial.
<i>Triple Access Line</i>	A collective name for Line 1, Line 2 and Inquiry lines. Line 1 and Line 2 forms your extension number and are available both for incoming and outgoing calls. Inquiry can only be used for outgoing calls.

Index

A

Absence Information 77
 Accessories 108
 Headset 109
 Key panel 108
 Pull-out leaf 112
 Account Code 87
 Add Microsoft Outlook contacts 113
 Answer calls 36

B

Bypass 49

C

Call Forwarding
 External Follow-me 69
 Internal Follow-me 67
 Personal Number 70
 Call forwarding 67
 Call list 52
 Call Waiting 48
 Callback 47
 Central Directory 127
 Change ring signal for a Monitoring key 106
 Character map 57
 Checking the protocol 93
 Common Bell Group 85
 Common Speed Dialing numbers 49
 Conference 66
 Contacts 55
 Contacts (PhoneBook)
 Add name or number 58
 Add number from the Call List 61
 Character map 57
 Delete name or number 60
 Edit name or number 59
 Entering names and numbers 56
 Copyright 5
 Corporate Directory 123

D

Date presentation 98
 Declaration of conformity 5
 Description 7
 Display information 14
 Display menu keys 21
 Lamp indications 11
 Menu structure Dialog 4425 v. 1 phone 23
 Menu structure Dialog 4425 v. 2 phone 25
 Tones and signals 12
 Dial by a function key 49
 Dial by a Monitoring key 50
 Dial by Contacts (PhoneBook) 51
 DISA (Direct Inward System Access) 92
 Display backlight 102
 Display contrast 101
 Display information 14
 Display menu keys 21
 Display symbols 16
 Disposal of the product 6
 During calls 62
 Conference 66
 Handsfree 62
 Hold 63
 Microphone on or off 62
 Transfer 65

E

Emergency mode 88
 External Follow-me 69

F

Free on 2nd access 39
 Free Seating 35

G

General Deactivation 88
 Glossary 142

Group Call-pick-up 85
 Group features 85
 Group Hunting 86

H

Handset and loudspeaker volume 104
 Handsfree 62
 Headset 109
 Hold 63
 Hot-Line 91

I

Important user information 6
 Incoming calls 36

- Answer a second call 39
- Handsfree 37
- On another extension 37
- On Line 1 36
- On Line 2 or Monitoring key 36
- Parallel Ringing 40

 Individual External Line 44
 Inquiry 64
 Installation 132
 Internal Follow-me 67
 Internal messages 80
 Intrusion 48

K

Key Monitoring 90, 91
 Key panel 108

L

Lamp indications 11
 LAN access control (network authentication) 28
 Language 96
 Last External Number Redial 44
 Log off 34
 Log on 31

M

Mailbox 84
 Make calls 42
 Malicious Call Tracing 91
 Manual Message Waiting (MMW) 80
 Menu structure Dialog 4425 v. 1 phone 23
 Menu structure Dialog 4425 v. 2 phone 25
 Message Waiting 81
 Messages 80

- Manual Message Waiting (MMW) 80
- Message Waiting 81

Voice Mail 82
 Mute 62
 Mute ring signal 105
 My Dialog 4000 Contacts 113

N

Network settings 107
 Night Service 89
 Number Presentation Restriction 46

O

Option unit 103
 Other useful facilities 87
 Outgoing calls 42

- Bypass 49
- Call Waiting 48
- Callback 47
- External calls 42
- Handsfree 43
- Individual External Line 44
- Internal calls 42
- Intrusion 48
- Last External Number Redial 44
- Number Presentation Restriction 46
- Redial calls from the Call List 45
- SOS calls (Emergency calls) 43
- Speed Dialing 49
- When you receive a busy tone 47

P

Parallel Ringing 40
 Personal Number 70
 PhoneBook 55
 Programming of function keys 93
 Programming of ring signal tone character 100
 Protocol 93
 Pull-out leaf 112

R

Redial calls from the Call List 45
 Refer Back 65
 Reset the phone 34
 Ring signal volume 105
 Ring signals 13

S

Safety instructions 6, 27
 Setting form for search profiles 76
 Settings 93

- Backlight 102

- Change ring signal for a Monitoring key 106
 - Date presentation 98
 - Display contrast 101
 - Handset and loudspeaker volume 104
 - Language 96
 - Mute ring signal 105
 - Network settings 107
 - Option unit 103
 - Programming of function keys 93
 - Programming of ring signal tone character 100
 - Ring signal volume 105
 - Silent Ringing 105
 - Time presentation 99
 - Short numbers 49
 - Silent Ringing 105
 - SOS calls (Emergency calls) 43
 - Speed Dialing 49
 - Start the phone 27
 - LAN access control (network authentication) 28
 - Log off 34
 - Log on 31
 - Start 27
 - Update software 30
- T**
- Time presentation 99
 - To access your IP phone from a PC 117
 - Tones and signals 12
 - Transfer 65
 - Troubleshooting 141
- U**
- Update software 30
- V**
- Voice Mail 82
 - Volume 104
- W**
- WAP Services 127
 - Warranty 5
 - Web 125
 - Web server 115
 - Welcome 4
 - When you receive a busy tone 47

Subject to alteration without prior notice.
For questions regarding the product, please contact your Aastra
Certified Sales Partner.
Also visit us on <http://www.aastra.com>

© Aastra Telecom Sweden AB 2009. All rights reserved.
EN/LZT 103 64 R8A